

LOW DISTORTION LINE MATCHING TRANSFORMER

P5097

Features

- * Lead-free (Pb-free)
- * RoHS compliant
- * Low Distortion
- * 11mm (0.43") Seated Height
- * Industry Standard Pinout
- * IEC 60950 and UL 60950 Certified
- * UL Recognized Component
- * Extended Frequency Response
- * Flat TX and RX Responses
- * High Thermal Stability
- * Directly replaces 82097

Applications

- * V.90 and V.92 Modems
- * V.34 Modems

DESCRIPTION

P5097 is intended for low cost V.90 and V.92 (56kbps) modems and other high-speed applications where low distortion at moderate power levels and very low voiceband frequencies is required.

P5097 is offered as a direct replacement for 82097 in existing circuits without changes to matching components.

P5097 exhibits stable core characteristics over its operating temperature range to maximize data throughput under varying environmental conditions without the need for modem retraining.

P5097 uses patented design and construction methods to achieve excellent signal performance and safety isolation to international standards. The part is completely lead-free, compliant with RoHS Directive 2002/95/EC, and suitable for lead-free and conventional processing.

P5097 is certified to IEC 60950 and UL 60950. P5097 is a UL Recognized Component and is supported by an IEC CB certificate.

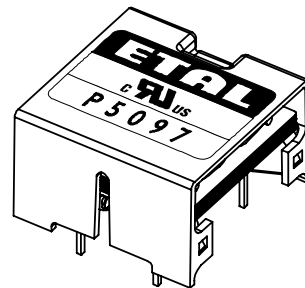

FOR NEW DESIGNS
P5056 IS RECOMMENDED

Patented



SPECIFICATIONS

Electrical

At T = 25°C and as circuit Fig. 2 unless otherwise stated.

Parameter	Conditions	Min	Typ	Max	Units
Insertion Loss	f = 2kHz, R _L = 600Ω	-	-	2.0	dB
Frequency Response	LF -3dB cutoff	-	10	-	Hz
	HF -3dB cutoff	-	30	-	kHz
	100Hz – 4kHz	-	-	±0.1	dB
Return Loss ⁽⁵⁾	200Hz – 4kHz	20	-	-	dB
Transhybrid Loss ⁽⁵⁾	200Hz – 4kHz	-	-	-	dB
Third Harmonic Distortion ⁽¹⁾	150Hz -3dBm in line	-	-	-76	dBm
Balance	DC – 5kHz Method TG 25	80	-	-	dB
Voltage Isolation ⁽²⁾	50Hz	2.12	-	-	kVrms
	DC	3.0	-	-	kV
Operating Range:	Functional	0	-	+70	°C
	Storage	-40	-	+85	°C

Lumped equivalent circuit parameters as Fig. 1

DC resistance ⁽³⁾ R _{DC}	Primary resistance R _{DCp}	120	-	149	Ω
	Secondary resistance R _{DCs}	117	-	143	Ω
Leakage inductance, ΔL		3.5	4.5	5.5	mH
Shunt inductance, L _p ⁽⁴⁾	200Hz 10mV	8	-	-	H
Shunt loss, R _p	200Hz 10mV	15	-	-	kΩ

Notes:

1. Third harmonic typically exceeds other harmonics by 10dB.
2. Components are 100% tested at 3.25kVDC.
3. Caution: do not pass DC through windings. Telephone line current must be diverted using semiconductor line hold circuit or choke.
4. At signal levels greater than 100mV, L_p will increase and R_p will decrease slightly but the effect is usually favourable to the return loss characteristic.
5. Return loss and transhybrid loss can be improved to 30dB in improved matching circuit. The values shown relate to the simplest configuration, Fig. 2.

Equivalent Circuit

Fig. 1

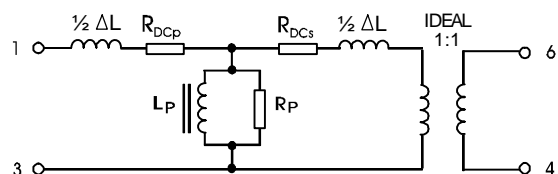

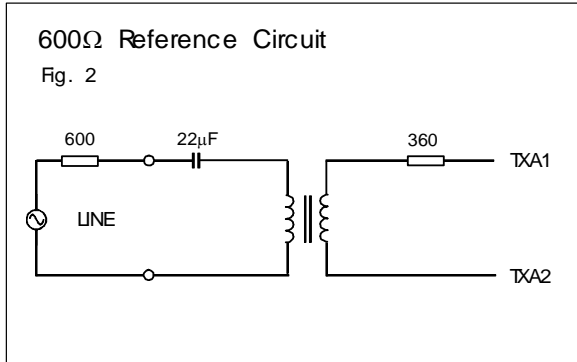

CONSTRUCTION

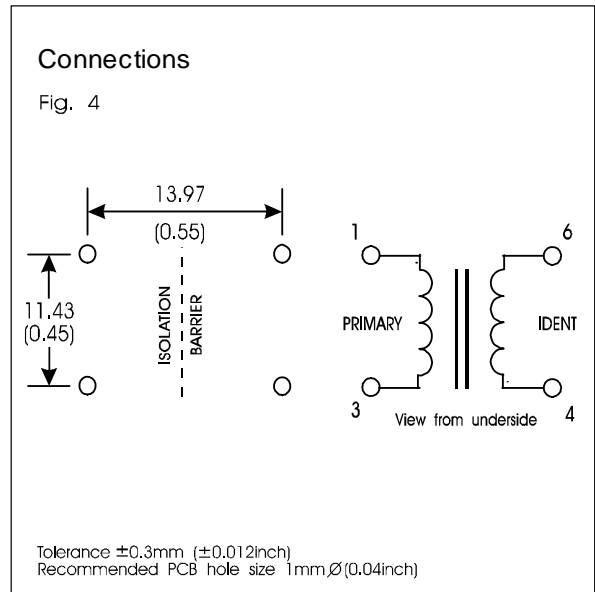
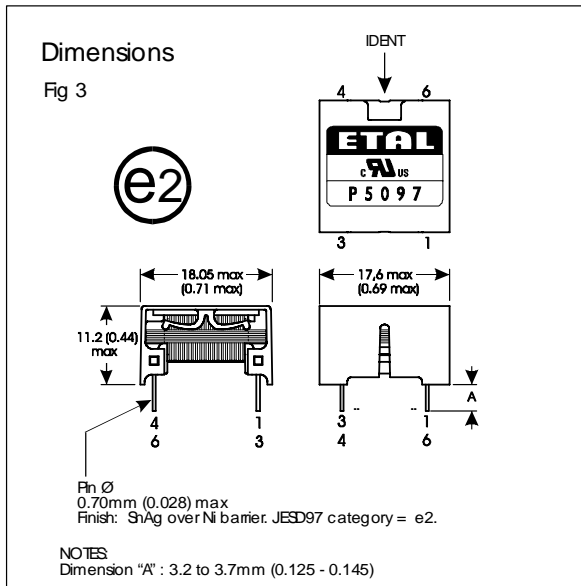

Dimensions shown are in millimetres (inches).
Geometric centres of outline and pin grid coincide within a tolerance circle of $0.6\text{mm}\varnothing$.
Windings may be used interchangeably as primary or secondary.
Total weight typically 5.5g.

Patented

SAFETY

Constructed in accordance with IEC 60950-1, EN 60950-1 and UL 60950-1, supplementary insulation for a primary circuit, 250Vrms maximum working voltage, flammability class V-1.

CERTIFICATION

Certified under the IEC CB scheme (Certificate GB597W) to IEC 60950 Third Edition 1999 sub-clauses 1.5, 1.5.1, 1.5.2, 2.9, 2.9.1, 2.9.2, 2.9.3, 2.9.4, 2.9.5, 2.10, 2.10.1, 2.10.2, 2.10.3, 2.10.3.1, 2.10.3.2, 2.10.4, 2.10.5, 2.10.5.1, 2.10.5.2, 2.10.5.4, 4.7, 4.7.3, 4.7.3.1, 4.7.3.4, (Flammability Class V-1), 5.2, 5.2.1, and 5.2.2 for a maximum working voltage of 250Vrms, nominal mains supply voltage not exceeding 300Vrms and a maximum operating temperature of +85°C in Pollution Degree 2 environment, supplementary insulation for a primary circuit.

Recognized under the Component Recognition Program of Underwriters Laboratories Inc. to US and Canadian requirements CAN/CSA C22.2 No. 60950-1-03/UL60950-1, First Edition, based on IEC 60950-1, First Edition, maximum working voltage 250Vrms, Pollution Degree 2, supplementary insulation.

UL File number E203175.

Additionally, Profec Technologies certifies all transformers as providing voltage isolation of 2.12kVrms, 3kV DC minimum. All shipments are supported by a certificate of conformity to current applicable safety standards.

ABSOLUTE MAXIMUM RATINGS

(Ratings of components independent of circuit).

Short term isolation voltage (1s)	2.12kVrms, 3.0 kVDC
DC current	100µA
Storage temperature	-40°C to +85°C
Lead temperature, 10s	260°C

INTELLECTUAL PROPERTY RIGHTS

ETAL and P5097 are Trade Marks of Profec Technologies Ltd.

The Trade Mark ETAL is registered at the UK Trade Marks Registry.

Profec Technologies Ltd. is the owner of the design right under the Copyright Designs and Patents Act 1988 and no rights or licences are hereby granted or implied to any third party.

P5097 design and construction are protected by patents.

British Patent No. 2333646.

US Patent Nos. 6,344,787; 6,690,254.

European Patent No. 1082734

China Patent No. ZL 99806739.3

Other patents pending.

© 1998 - 2005 Profec Technologies Ltd.

Reproduction prohibited.



ETAL Group Oy, Kuormatie 14, FIN-03101, Nummela
Telephone: +358 (0)20 7500 330 Fax: +358 (0)20 7500 333
Website: www.etalgroup.com Email: etalgroup@egruppen.com