

1 2 3 4 5 6 7 8 9 10

NOTE:
1. GENERAL TOLERANCES MAX. ±0.20mm.

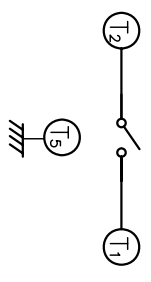

CIRCUIT DIAGRAM

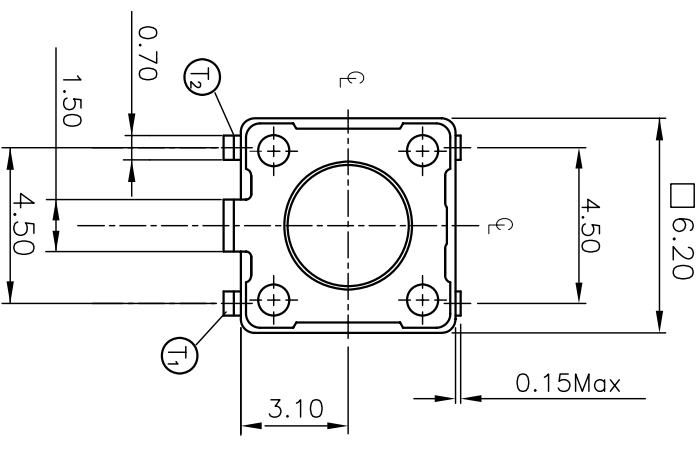
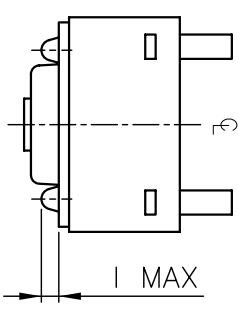
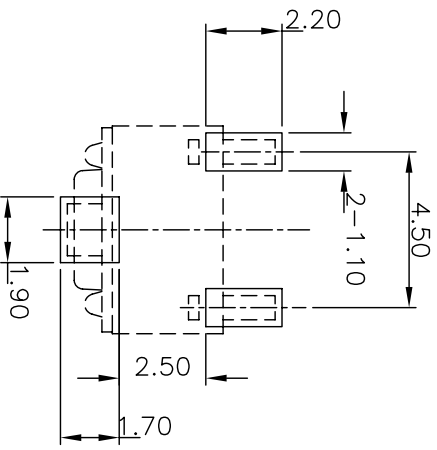
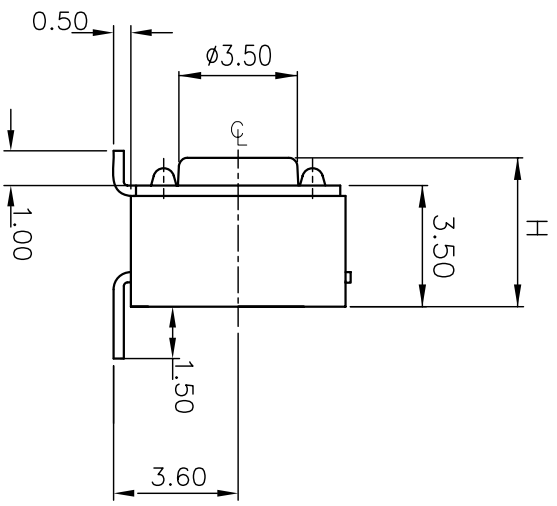

P.C.B. LAYOUT

DTSAMG-62~66-Q	0.5 MAX
DTSAMG-61-Q	0.4 MAX
PROD. NO.	I
DTSAMG-66-Q	13.0
DTSAMG-65-Q	9.5
DTSAMG-63-Q	7.0
DTSAMG-62-Q	5.0
DTSAMG-61-Q	4.3
PROD. NO.	H

APPD:	QTY:	SCALE:	7 : 1
CHKD:	SCALE:	UNITS:	mm
DR:	PAGGY	REV:	A
DESIGN:			
ZONE/REV:	A	DWG.REL.	
		DESCRIPTION	
		DATE	APPD.

國達實業股份有限公司	DIPTRONICS MANUFACTURING, INC.
DTSAMG-60□-Q	MAT'L:
DTSAMG-60□-Q	FINISH:
PART NAME:	TACTILE SWITCH 6X6 (WITH GROUND TERMINAL)
DWG NO:	DTSAMG-60□-Q