

**380-001**  
**EMI/RFI Non-Environmental Backshell**  
**with Strain Relief**  
**Type A - Rotatable Coupling - Low Profile**

**CONNECTOR DESIGNATOR**  
**A-F-H-L-S**  
**ROTATABLE COUPLING**  
**TYPE A OVERALL SHIELD TERMINATION**

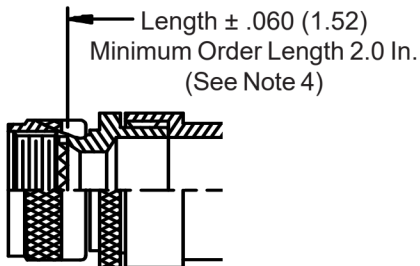

**STYLE 2 (STRAIGHT)**  
 See Note 1)

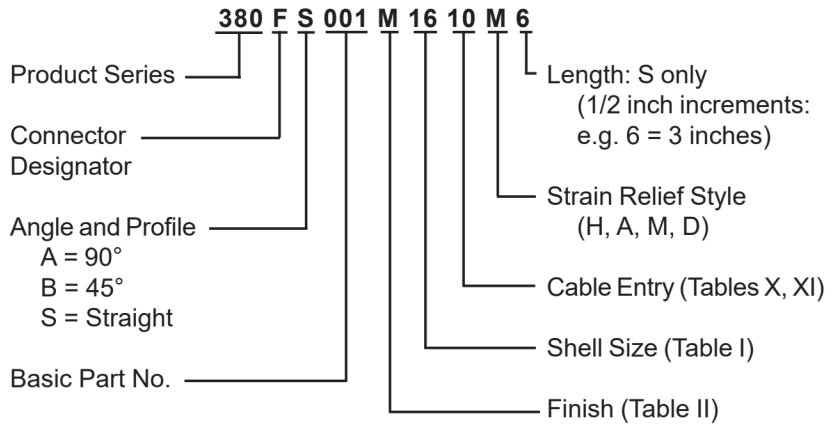
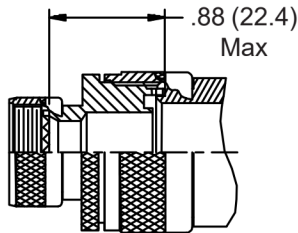

**STYLE 2 (45° & 90°)**  
 See Note 1)

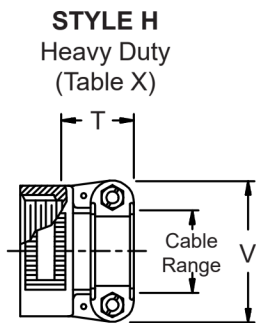
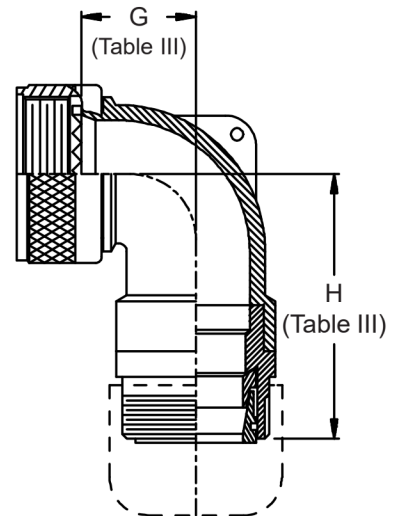
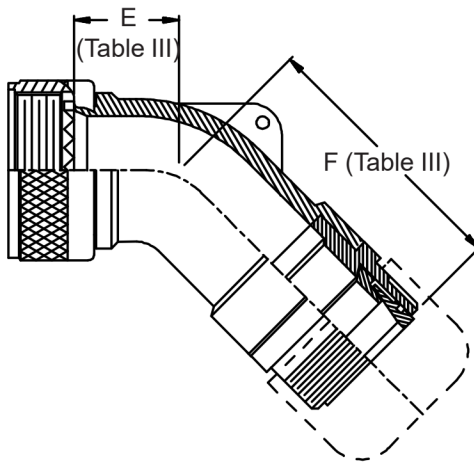
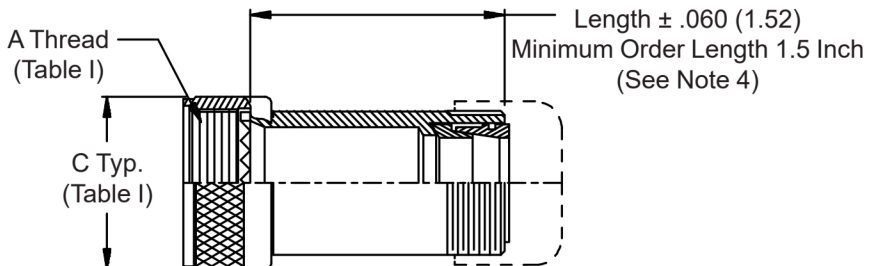

**STYLE H Heavy Duty**  
 (Table X)

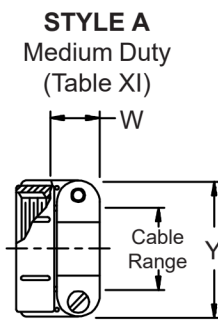

**STYLE A Medium Duty**  
 (Table XI)

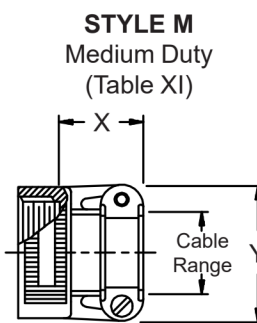

**STYLE M Medium Duty**  
 (Table XI)

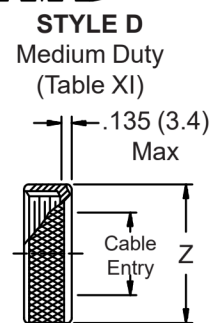

**STYLE D Medium Duty**  
 (Table XI)

