

USED ON.	NEXT ASSY.	REV.	ECN No.	DATE.	NAME.	SIGN.

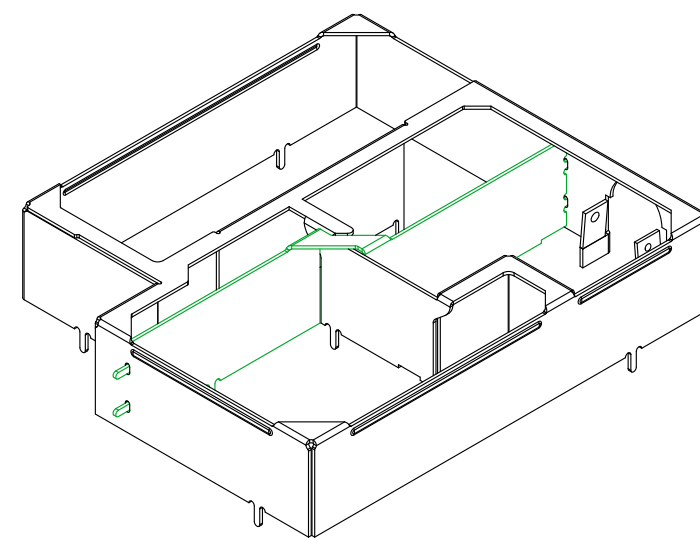

- Note**
1. TS275E 8.4/8.4
 2. Electrolytic Tin Plate As Per EN 10202 : 2001
Min Tin Thickness 3.5 µm
 3. General tolerance ±0.2mm
Non Dimensioned items remain **MASACH** property.

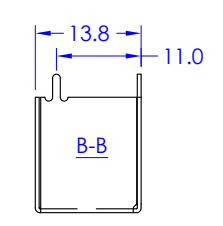
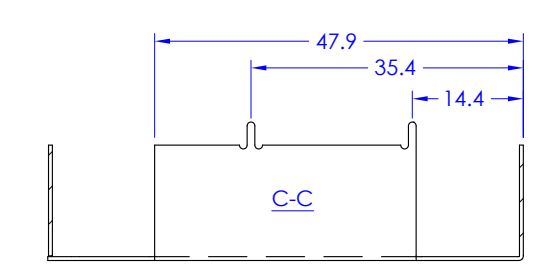
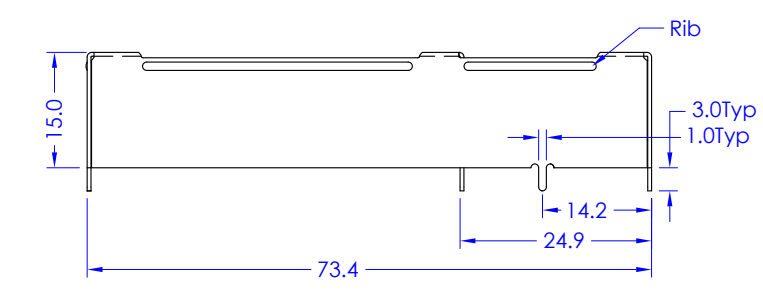
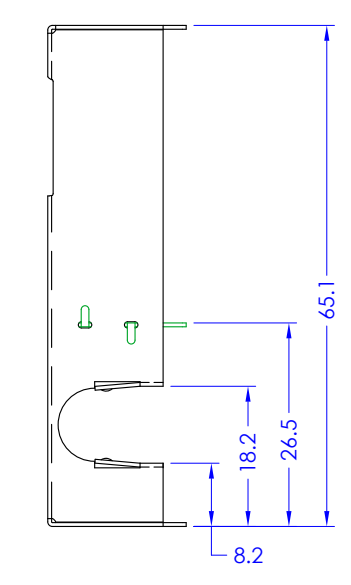
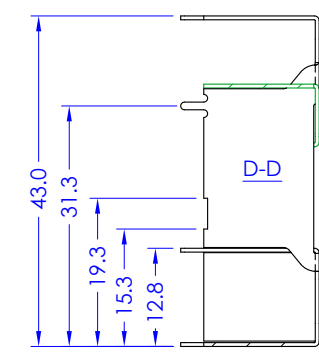
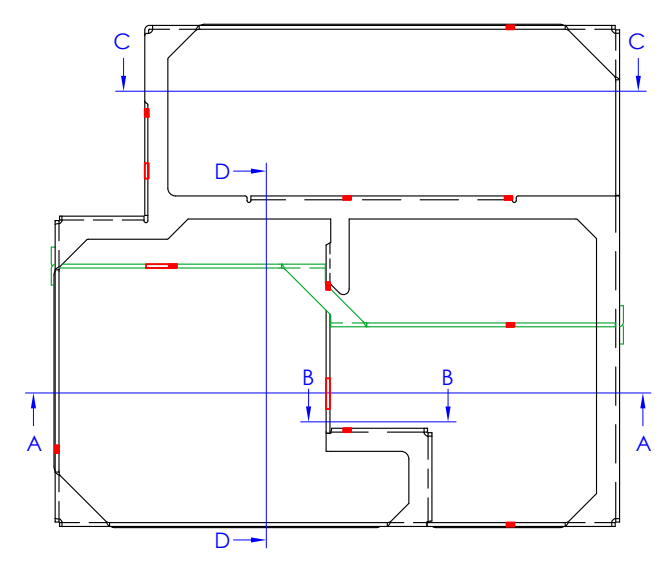
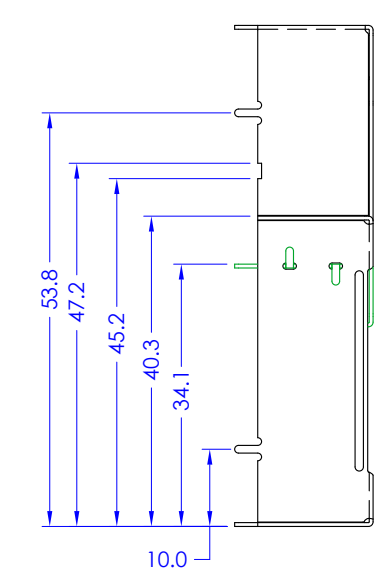
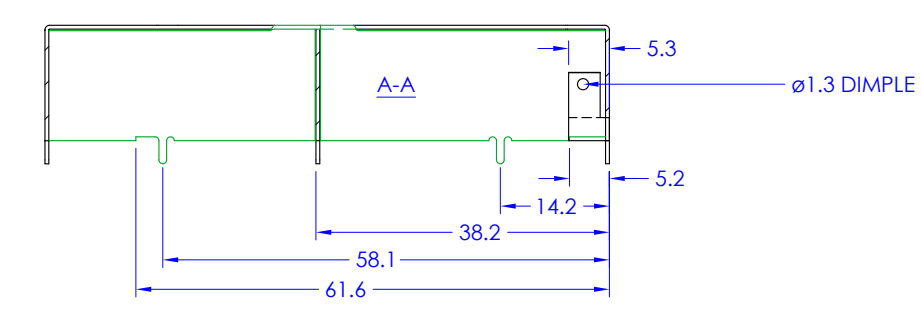
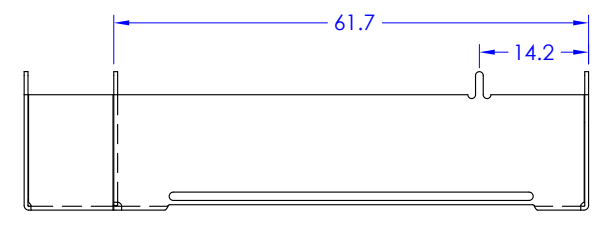

		COMPANY:	INTEL	DESCRIPTION:	RF FRAME		
		DES.	AMIHAI	17.12.15	ITEM No:		INL013F
DR.							
CHK.							
APP.				MATERIAL:	TIN STEEL 0.5mm (See Note 1,2)	FINISH:	
QA.							
						SCALE 1:1	A3