

ASJ

DATA SHEET

Metal Alloy Low-Resistance Resistor

CLS Series

0.5% To 5%, TCR ± 25 To ± 175

SIZE: 1206/2010/2512/2725/2728/4527/4527S

RoHS-Compliant



METAL ALLOY LOW-RESISTANCE CHIP RESISTOR

CLS Series

DS-ENG-007

Page: 2 of 29

1. SCOPE

- 1.1. This specification is applicable to Lead-free, Halogen-free of RoHS Directive for metal alloy low-resistance resistor.
- 1.2. The product is for general purpose.

2. PART NUMBERING SYSTEM

Part Numbering is made in accordance with the following system:

CLS	63	1	-	R100	-	F	E
Type	Size(Inch)	Power Rting	Nominal Resistance		Tolerance	Packaging	
Metal Alloy Low-Resistance Resistor	32(1206)	A=0.5W	Resistor	Resistance (4~6 Digit) EX: R001 = 1mΩ R010 = 10mΩ R100 = 100mΩ R00025 = 0.25mΩ	D=±0.5% F=±1.0% G=±2.0% J=±5.0%	T=500 pcs Q=1,000 pcs P=2,000 pcs E=4,000 pcs	
	40(1210)	1=1.0W					
	50(2010)	B=1.5W					
	63(2512)	2=2.0W					
	27(2725)	3=3.0W					
	28(2728)	D=3.5W					
	45(4527)	4=4.0W					
45S(4527S)	5=5.0W						

3. RATING

- 3.1. Rated Power
 - 3.1.1 Resistor Rated Power

Type	Max. Rating Power	Max. Rating Current	Max. Overload Current
CLS32	0.5W	$I_r = \sqrt{P/R}$	$I_o = \sqrt{5 P/R}$
	1W		
	1.5W		
	2W		
CLS40	1.5W		
CLS50	1W		
	1.5w		
	2W		
CLS63	1W		
	1.5W		
	2W		
	3W		
CLS27	4W		
	5W		
CLS28	3W		
	3.5W		
	4W		
CLS45S (without heat sink)	2W		
	3W		
	5W		
CLS45	5W		



3.1.2 Power Derating Curve: Operating Temperature Range : - 55 ~+170 °C
For resistors operated in ambient temperatures 70°C, power rating shall be derated in accordance with the curve below:

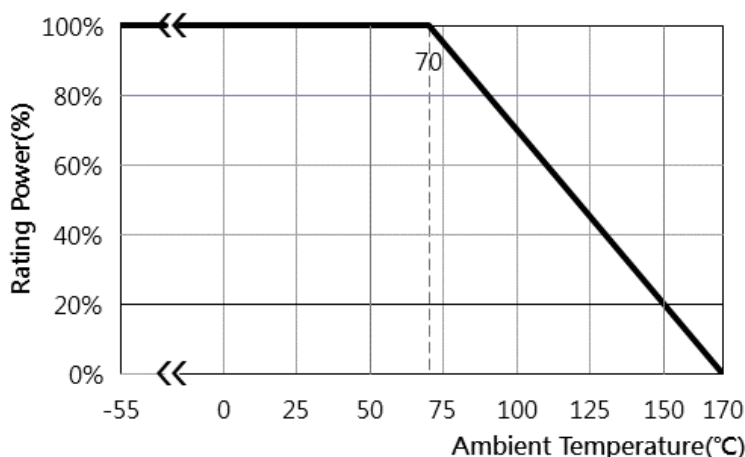

Fig.1 Power Derating Characteristics

3.2 Standard Atmospheric Condition

Unless otherwise specified, the standard range of atmospheric conditions for making measurements and tests is as follows:

Ambient Temperature = +5°C to +35°C

Relative Humidity = < 85% RH

Air Pressure = 86 to 106kPa

If there may be any doubt about the results, measurement shall be made within the following limits :

Ambient Temperature = 20± 2°C

Relative Humidity = 60 to 70% RH

Air Pressure = 86 to 106kPa

3.3 Operating Temperature Range -55°C to +170°C,

3.4 Storage Temperature Range -5°C to +40°C / < 85% RH

3.5 Flammability Rating Tested in accordance to UL-94, V-0

3.6 Moisture Sensitivity Level Rating: Level 1

3.7 Product Assurance

ASJ resistor shall warranty 24 months from manufacturing date with control conditions.

3.8 ASJ resistors are RoHS-compliant in accordance to RoHS Directive.

METAL ALLOY LOW-RESISTANCE CHIP RESISTOR

CLS Series

DS-ENG-007

Page: 4 of 29

3.9 Resistance, Resistance Tolerance and Temperature Coefficient of Resistance

Type	# of Terminals	Rating Power	Rating Current	Overload Current	T.C.R. (ppm/°C)	Resistance Range (mΩ)		Operating Temperature Range
						D (±0.5%)	F (±1%) G (±2%) J (±5%)	
1206	2	0.5W			0.5~0.6 mΩ: ≤±175 1~1.5 mΩ: ≤±75 2~4 mΩ: ≤±75 5~15 mΩ: ≤±75 15.1~50 mΩ: ≤±50	5 ~ 50	0.5 ~ 50	-55~170°C
		1W			0.5~0.6 mΩ: ≤±175 1~1.5 mΩ: ≤±75 2~4 mΩ: ≤±75 5~15 mΩ: ≤±75 15.1~50 mΩ: ≤±50	5 ~ 50	0.5 ~ 50	
		1.5W			0.5~0.6 mΩ: ≤±175 1~1.5 mΩ: ≤±75 2~4 mΩ: ≤±75 5 mΩ: ≤±75	5	0.5 ~ 5	
		2W			0.5~0.6 mΩ: ≤±175 1~1.5 mΩ: ≤±75 2~4 mΩ: ≤±75 5 mΩ: ≤±75	5	0.5 ~ 5	
1210		1.5W			2~10 mΩ: ≤±75	2 ~ 10	2 ~ 10	
2010		1W	$I_r = \sqrt{P/R}$	$I_o = \sqrt{5 P/R}$	0.5~0.9 mΩ: ≤±100 1~1.9 mΩ: ≤±75 2~6.9 mΩ: ≤±50 7~100 mΩ: ≤±25	7 ~ 49	0.5~100	
		1.5W			0.5~0.9 mΩ: ≤±100 1~1.9 mΩ: ≤±75 2~6.9 mΩ: 7~40 ≤±50 mΩ: ≤±25	7 ~ 40	0.5~40	
		2W			0.5~0.9 mΩ: ≤±100 1~1.9 mΩ: ≤±75 2~6.9 mΩ: ≤±50 7~12 mΩ: ≤±25	7 ~ 12	0.5~12	
2512	2	1W			0.3 mΩ: ≤±150 0.5~0.7 mΩ: ≤±75 0.75 mΩ: ≤±75 0.8~1 mΩ: ≤±75 1.1~3 mΩ: ≤±50 3.1~100 mΩ: ≤±25 101~300 mΩ: ≤±50 301~500 mΩ: ≤±50	1 ~ 50	0.3 ~ 500	
		1.5W			0.3 mΩ: ≤±150 0.5~0.7 mΩ: ≤±75 0.75 mΩ: ≤±75 0.8~1 mΩ: ≤±75 1.1~3 mΩ: ≤±50 3.1~100 mΩ: ≤±25 101~220 mΩ: ≤±50	1 ~ 50	0.3 ~ 220	



METAL ALLOY LOW-RESISTANCE CHIP RESISTOR

CLS Series

DS-ENG-007

Page: 5 of 29

Type	# of Terminals	Rating Power	Rating Current	Overload Current	T.C.R. (ppm/°C)	Resistance Range (mΩ)		Operating Temperature Range
						D (±0.5%)	F (±1%) G (±2%) J (±5%)	
2512		2W			0.3 mΩ: $\leq \pm 150$ 0.5~0.7 mΩ: $\leq \pm 75$ 0.75 mΩ: $\leq \pm 75$ 0.8~1 mΩ: $\leq \pm 75$ 1.1~3 mΩ: $\leq \pm 50$ 3.1~75 mΩ: $\leq \pm 25$ 80~100 mΩ: $\leq \pm 25$ 101~150 mΩ: $\leq \pm 50$ 151~299 mΩ: $\leq \pm 75$ 300~500 mΩ: $\leq \pm 50$	1 ~ 50	0.3 ~ 500	
		3W			0.3 mΩ: $\leq \pm 150$ 0.5~0.7 mΩ: $\leq \pm 75$ 0.75 mΩ: $\leq \pm 75$ 0.8~1 mΩ: $\leq \pm 75$ 1.1~2.5 mΩ: $\leq \pm 50$ 2.6~10 mΩ: $\leq \pm 25$ 50~150 mΩ: $\leq \pm 50$	1 ~ 10	0.3 ~ 10 50 ~ 150	
2725		4W			0.20 mΩ: $\leq \pm 100$ 0.25~3 mΩ: $\leq \pm 50$	--	0.20 ~ 3	
		5W			0.20 mΩ: $\leq \pm 100$ 0.25~0.5 mΩ: $\leq \pm 50$	--	0.20 ~ 0.5	
2728	2	3W	$I_r = \sqrt{P/R}$	$I_o = \sqrt{5 P/R}$	4~200 mΩ: $\leq \pm 25$	4 ~ 19	4 ~ 200	
		3.5W			4~100 mΩ: $\leq \pm 25$	4 ~ 19	4 ~ 100	
		4W			4~80 mΩ: $\leq \pm 25$	4 ~ 19	4 ~ 80	
4527S (without heat sink)		2W			0.5 mΩ: $\leq \pm 75$ 0.6~1 mΩ: $\leq \pm 75$ 1.1~3 mΩ: $\leq \pm 50$ 4~5 mΩ: $\leq \pm 50$ 5.1~200 mΩ: $\leq \pm 50$	7 ~ 100	0.5 ~ 200	
		3W			0.5 mΩ: $\leq \pm 75$ 0.6~1 mΩ: $\leq \pm 75$ 1.1~3 mΩ: $\leq \pm 50$ 4~5 mΩ: $\leq \pm 50$ 5.1~27 mΩ: $\leq \pm 50$	7 ~ 27	0.5 ~ 27	
		5W			0.5 mΩ: $\leq \pm 75$ 0.6~1 mΩ: $\leq \pm 75$ 1.1~3 mΩ: $\leq \pm 50$ 4~5 mΩ: $\leq \pm 50$ 5.1~7.5 mΩ: $\leq \pm 50$	7 ~ 7.5	0.5~7.5	
4527		5W			0.5 mΩ: $\leq \pm 75$ 0.6~1 mΩ: $\leq \pm 75$ 1.1~3 mΩ: $\leq \pm 50$ 4~5 mΩ: $\leq \pm 50$ 5.1~200 mΩ: $\leq \pm 50$	7 ~ 120	0.5 ~ 200	

I_r = Rating Current (A) P = Rating Power (W)
 I_o = Overload Current (A) R = Resistance (Ω)



Product Specification

Towards Excellence in Quality, Service & Innovation

3.10 Rating Current

The following equation may be used to determine the DC (Direct Current) or AC (Alternative Current) currents (RMS, root mean square value) of normal rated power. However, if the result value exceeds the highest current of regulated standards, the highest normal rated power is to be used.

Remark:

$$I = \sqrt{P/R}$$

I=Rating Current (A)

P= Rating Power (W)

R=Resistance (Ω)

4. MARKING FOMAT

4.1 Product resistance is indicated by using two marking notation style:

- a. "R" designates the decimal location in ohm, e.g.
 - For 5mΩ the product marking is R005
 - For 25mΩ the product marking is R025
 - For 100mΩ the product marking is R100
- b. "m" designates the decimal location in milliohms, e.g.
 - For 5.5mΩ the product marking is 5m50
 - For 25.5mΩ the product marking is 25m5

4.2 Numeric Numbering

4.2.1 CLS32 Series: (4 digits marking)

4.2.1.1 Above 1.0mΩ & 0.3mΩ

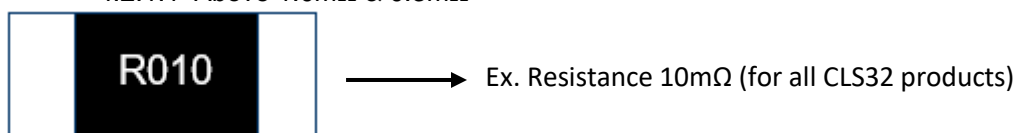

4.2.2 0.5~0.6 mΩ:(Square marking)
Recognize Top/Bottom side



4.2.2.1 CLS40 series: (4 digits marking)

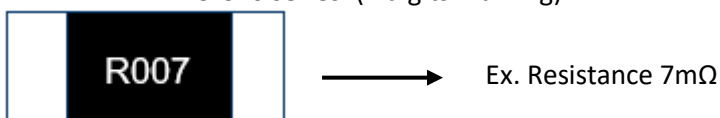

4.2.3 CLS50 Series: (4 digits marking)

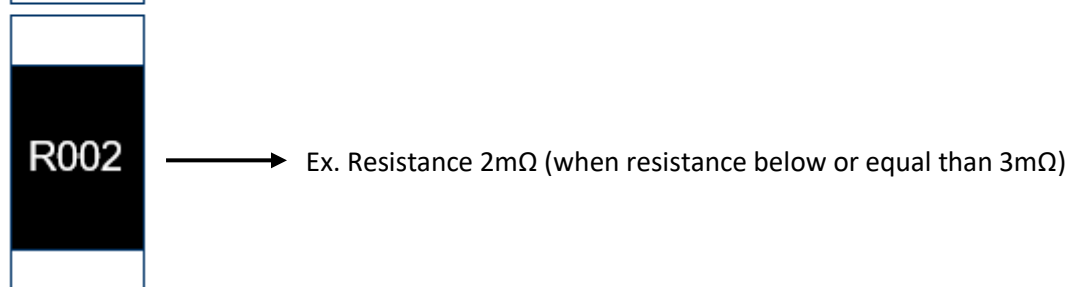
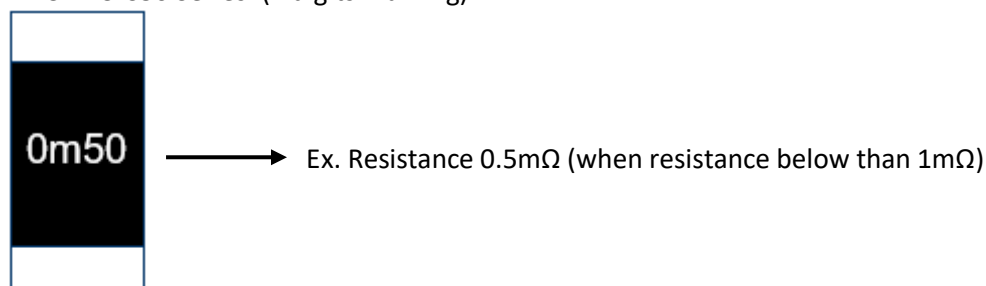

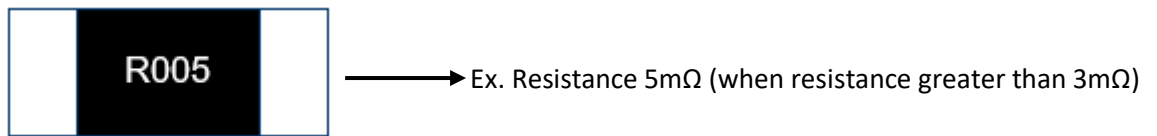

4.2.4 CLS63 Series: (3 digits marking / 4 digits marking)

4.2.4.1 $\leq 4.0\text{m}\Omega$ (3-digits marking)

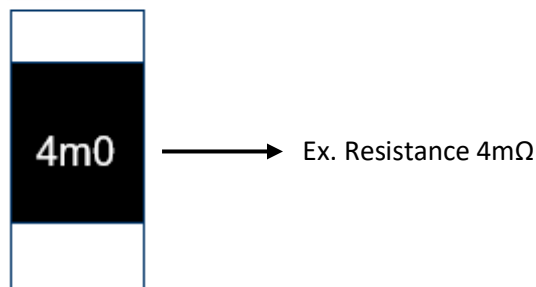
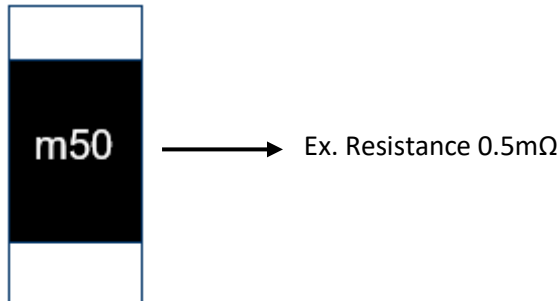

4.2.4.2 $> 4.0\text{m}\Omega$ (4-digits marking)

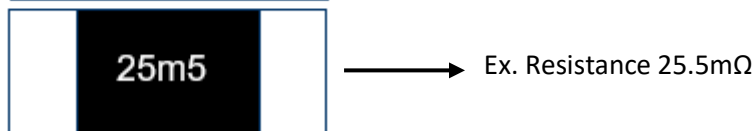
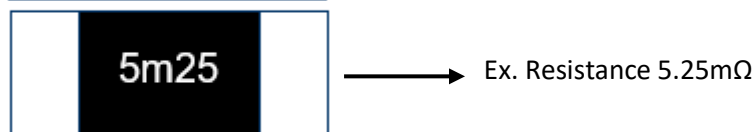
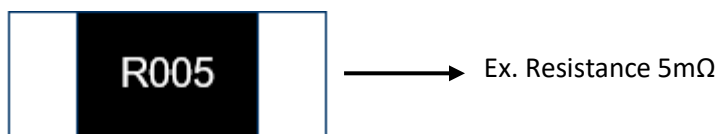

4.2.5 CLS63 Series 2 Watts, 80 ~ 100 mΩ (4-digits marking)

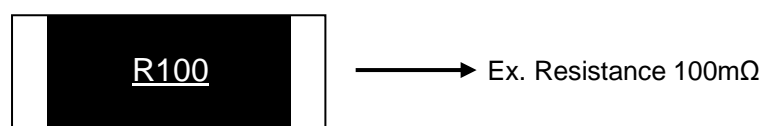
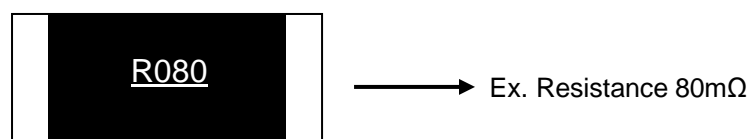

4.2.6 CLS27 Series: (4-digits marking)

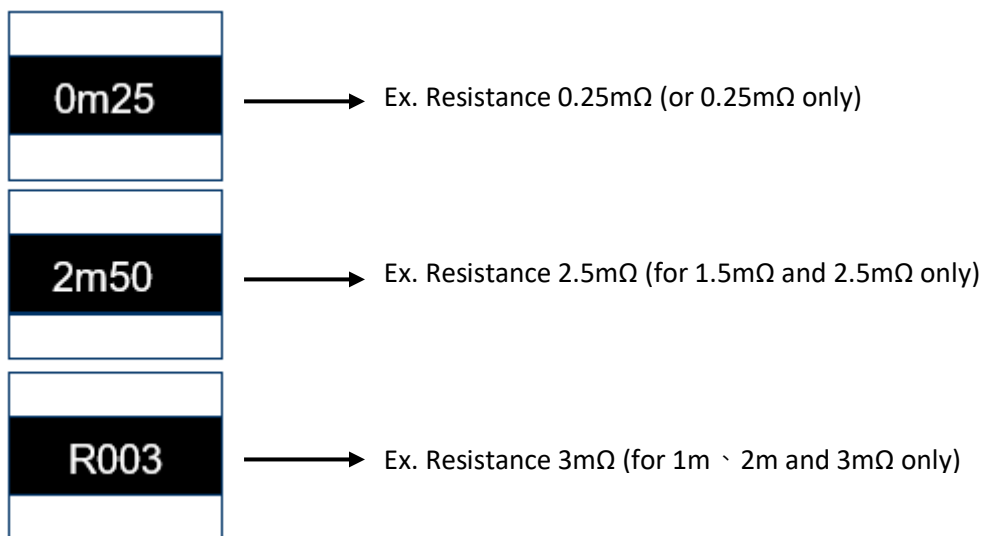

4.2.7 CLS28 Series: (4 digits marking)

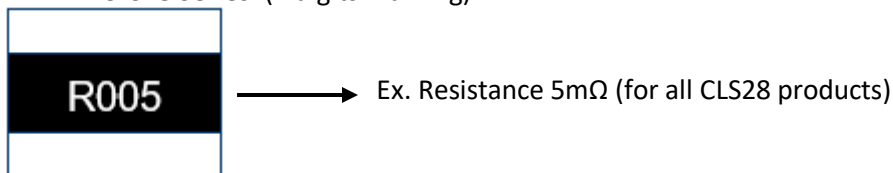

4.2.8 CLS45 Series: (4 digits marking)



4.2.8 CLS45S Series: (4 digits marking)

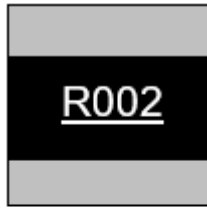

Ex: Resistance 2mΩ.

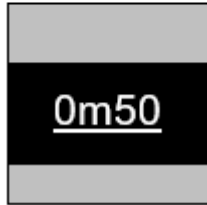

Ex: Resistance 0.5mΩ.

4.3 Marking Style

Type \ Marking	R	m	1	2	3	4	5	6	7	8	9	0
CLS32	R	m	1	2	3	4	5	6	7	8	9	0
CLS40												
CLS50												
CLS63												
CLS27												
CLS28												
CLS45												
CLS45S												

METAL ALLOY LOW-RESISTANCE CHIP RESISTOR

CLS Series

DS-ENG-007

Page: 11 of 29

5. DIMENSION

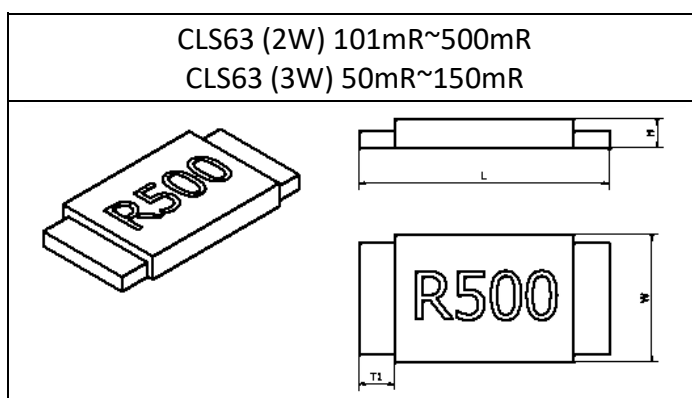
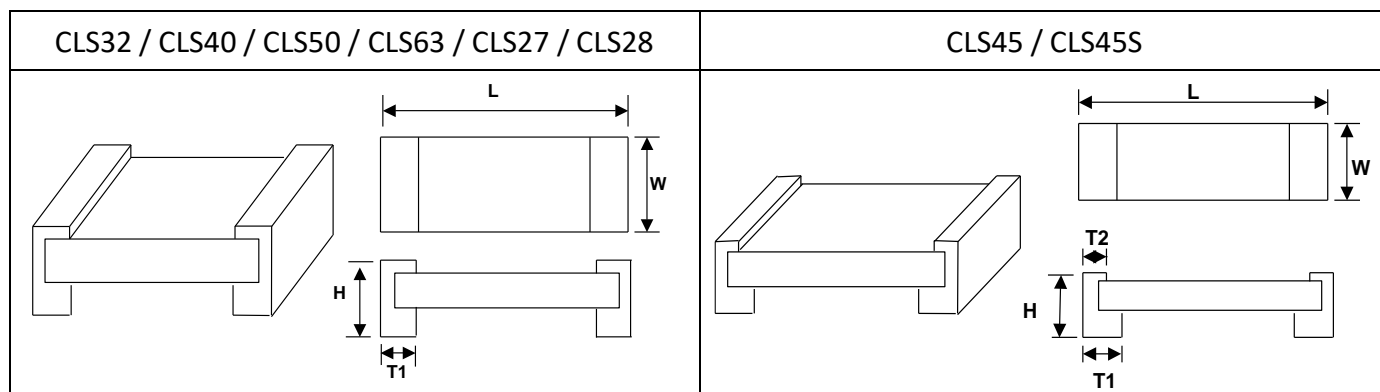

Type	Power Rating (Watts)	Resistance Range (mΩ)	Dimensions - in inches (millimeters)				
			L	W	H	T1	T2
CLS32	0.5 1	0.5 ~ 0.6	0.126±0.010 (3.200±0.254)	0.063±0.010 (1.600±0.254)	0.039±0.010 (1.000±0.254)	0.029±0.010 (0.725±0.254)	
		1 ~ 1.5			0.025±0.010 (0.645±0.254)	0.020±0.010 (0.508±0.254)	
		2 ~ 4			0.022±0.010 (0.545±0.254)	0.024±0.010 (0.600±0.254)	
		5				0.020±0.010 (0.508±0.254)	
		6 ~ 50				0.020±0.010 (0.508±0.254)	
	1.5 2	0.5 ~ 0.6			0.039±0.010 (1.000±0.254)	0.029±0.010 (0.725±0.254)	
		1.0 ~ 1.5			0.025±0.010 (0.645±0.254)	0.020±0.010 (0.508±0.254)	
		2 ~ 4			0.022±0.010 (0.545±0.254)	0.024±0.010 (0.600±0.254)	
		5				0.020±0.010 (0.508±0.254)	
						0.020±0.010 (0.508±0.254)	
CLS40	1.5	2 ~ 10	0.126±0.010 (3.20±0.254)	0.100±0.010 (2.54±0.254)	0.035±0.010 (0.88±0.254)	0.024±0.010 (0.60±0.254)	
CLS50	1	0.5 ~ 0.9	0.200±0.010 (5.080±0.254)	0.100±0.010 (2.540±0.254)	0.031±0.010 (0.787±0.254)	0.057±0.010 (1.440±0.254)	
	1.5					0.051±0.010 (1.295±0.254)	
	2	1 ~ 3					



Product Specification

Towards Excellence in Quality, Service & Innovation

METAL ALLOY LOW-RESISTANCE CHIP RESISTOR

CLS Series

DS-ENG-007

Page: 12 of 29

Type	Power Rating (Watts)	Resistance Range (mΩ)	Dimensions - in inches (millimeters)						
			L	W	H	T1	T2		
CLS63		3.1 ~ 4	0.246±0.010 (6.248±0.254)	0.126±0.010 (3.202±0.254)	0.025±0.010 (0.645±0.254)	0.031±0.010 (0.787±0.254)			
		4.1 ~ 100							
	1	0.3			0.040±0.010 (1.000±0.254)	0.079±0.010 (2.02±0.254)			
		0.5 ~ 0.7						0.031±0.010 (0.787±0.254)	0.079±0.010 (2.02±0.254)
		0.75							0.054±0.010 (1.374±0.254)
		0.8 ~ 3							0.074±0.010 (1.880±0.254)
		3.1 ~ 4						0.074±0.010 (1.880±0.254)	
		4.1 ~ 79						0.025±0.010 (0.645±0.254)	0.044±0.010 (1.118±0.254)
		80 ~ 200							0.034±0.010 (0.868±0.254)
		201 - 300						0.0236±0.010 (0.600±0.254)	0.034±0.010 (0.868±0.254)
		301 ~ 500						0.0283±0.010 (0.720±0.254)	
	1.5	0.3			0.040±0.010 (1.000±0.254)	0.079±0.010 (2.02±0.254)			
		0.5 ~ 0.7						0.031±0.010 (0.787±0.254)	0.079±0.010 (2.02±0.254)
		0.75							0.054±0.010 (1.374±0.254)
		0.8 ~ 3							0.074±0.010 (1.880±0.254)
		3.1 ~ 4						0.074±0.010 (1.880±0.254)	
		4.1 ~ 79						0.025±0.010 (0.645±0.254)	0.044±0.010 (1.118±0.254)
		80 ~ 200							0.034±0.010 (0.868±0.254)
		201 ~ 220						0.0236±0.010 (0.600±0.254)	0.034±0.010 (0.868±0.254)
		0.040±0.010 (1.000±0.254)							
	2	0.3			0.040±0.010 (1.000±0.254)	0.079±0.010 (2.02±0.254)			
		0.5 ~ 0.7						0.031±0.010 (0.787±0.254)	0.079±0.010 (2.02±0.254)
		0.75							0.054±0.010 (1.374±0.254)
		0.8 ~ 3							0.074±0.010 (1.880±0.254)
		3.1 ~ 4						0.074±0.010 (1.880±0.254)	
		4.1 ~ 75						0.025±0.010 (0.645±0.254)	0.044±0.010 (1.118±0.254)
		80 ~ 100							0.024±0.010 (0.624±0.254)
		101 ~ 500						0.0283±0.010 (0.720±0.254)	0.034±0.010 (0.868±0.254)
		0.040±0.010 (1.000±0.254)							
	3	0.3			0.040±0.010 (1.000±0.254)	0.079±0.010 (2.02±0.254)			
0.5		0.031±0.010 (0.787±0.254)	0.079±0.010 (2.02±0.254)						



Product Specification

Towards Excellence in Quality, Service & Innovation

METAL ALLOY LOW-RESISTANCE CHIP RESISTOR

CLS Series

DS-ENG-007

Page: 13 of 29

Type	Power Rating (Watts)	Resistance Range (mΩ)	Dimensions - in inches (millimeters)					
			L	W	H	T1	T2	
		0.6 ~ 0.7				0.074±0.010 (1.880±0.254)		
		0.75				0.054±0.010 (1.374±0.254)		
		0.8 ~ 2.9				0.044±0.010 (1.118±0.254)		
		3 ~ 3.5				0.074±0.010 (1.880±0.254)		
		3.6 ~ 4				0.066±0.010 (1.676±0.254)		
CLS63	3	4.1~10	0.246±0.010 (6.248±0.254)	0.126±0.010 (3.202±0.254)	0.025±0.010 (0.645±0.254)	0.044±0.010 (1.118±0.254)		
		50~150				0.0283±0.010 (0.720±0.254)		0.034±0.010 (0.868±0.254)
CLS27	4	0.2 ~ 0.3	0.268±0.010 (6.807±0.254)	0.254±0.010 (6.452±0.254)	0.039±0.010 (0.991±0.254)	0.085±0.010 (2.159±0.254)		
		0.35				0.075±0.010 (1.90±0.254)		
		0.4 ~ 0.45				0.051±0.010 (1.30±0.254)		
		0.5				0.085±0.010 (2.159±0.254)		
		0.6				0.071±0.010 (1.803±0.254)		
		0.75				0.059±0.010 (1.504±0.254)		
		1				0.043±0.010 (1.092±0.254)		0.085±0.010 (2.159±0.254)
		1.5						0.039±0.010 (0.991±0.254)
	5	2	0.268±0.010 (6.807±0.254)	0.254±0.010 (6.452±0.254)	0.035±0.010 (0.889±0.254)	0.071±0.010 (1.803±0.254)		
		2.25 ~ 2.5				0.065±0.010 (1.651±0.254)		
		3				0.051±0.010 (1.30±0.254)		
						0.085±0.010 (2.159±0.254)		
	5	0.2 ~ 0.3	0.268±0.010 (6.807±0.254)	0.254±0.010 (6.452±0.254)	0.039±0.010 (0.991±0.254)	0.085±0.010 (2.159±0.254)		
		0.35				0.075±0.010 (1.90±0.254)		
		0.4 ~ 0.45				0.051±0.010 (1.30±0.254)		
		0.5				0.085±0.010 (2.159±0.254)		
CLS28	3	4 ~ 200	0.264±0.010 (6.706±0.254)	0.283±0.010 (7.188±0.254)	0.039±0.010 (0.991±0.254)	0.045±0.010 (1.143±0.254)		
	3.5	4 ~ 100						
	4	4 ~ 80						



Product Specification

Towards Excellence in Quality, Service & Innovation

METAL ALLOY LOW-RESISTANCE CHIP RESISTOR

CLS Series

DS-ENG-007

Page: 14 of 29

Type	Power Rating (Watts)	Resistance Range (mΩ)	Dimensions - in inches (millimeters)									
			L	W	H	T1	T2					
CLS45S (without heat sink)	2	0.5	0.450±0.010 (11.430±0.254)	0.270±0.010 (6.850±0.254)	0.055±0.010 (1.400±0.254)	0.136±0.010 (3.465±0.254)	0.038±0.010 (0.965±0.254)					
		0.6 ~ 3				0.127±0.010 (3.215±0.254)						
		4 ~ 5				0.071±0.010 (1.815±0.254)						
		5.1 ~ 200				0.136±0.010 (3.465±0.254)						
	3	0.5				0.127±0.010 (3.215±0.254)						
		0.6 ~ 3				0.071±0.010 (1.815±0.254)						
		4 ~ 5				0.136±0.010 (3.465±0.254)						
		5.1 ~ 27				0.127±0.010 (3.215±0.254)						
	5	0.5				0.071±0.010 (1.815±0.254)						
		0.6 ~ 3				0.136±0.010 (3.465±0.254)						
		4 ~ 5				0.127±0.010 (3.215±0.254)						
		5.1 ~ 7.5				0.071±0.010 (1.815±0.254)						
	CLS45	5				0.5		0.450±0.010 (11.430±0.254)	0.270±0.010 (6.850±0.254)	0.059±0.010 (1.500±0.254)	0.136±0.010 (3.465±0.254)	0.038±0.010 (0.965±0.254)
						0.6 ~ 3					0.127±0.010 (3.215±0.254)	
						4 ~ 5					0.127±0.010 (3.215±0.254)	
						5.1 ~ 200					0.071±0.010 (1.815±0.254)	



Product Specification

Towards Excellence in **Quality, Service & Innovation**

METAL ALLOY LOW-RESISTANCE CHIP RESISTOR

CLS Series

DS-ENG-007

Page: 15 of 29

5.1 Material of Alloy

Type	Watts	Material	Resistance(R)
CLS32	0.5	Copper-Manganese Alloy	$\leq 4.0\text{m}\Omega$
	1.0	Iron-Chromium Aluminium Alloy	$> 4.0\text{m}\Omega$
	1.5		
	2.0		
CLS40	1.5	Copper-Manganese Alloy	$\leq 2.0\text{m}\Omega$
		Iron-Chromium Aluminium Alloy	$> 2.0\text{m}\Omega$
CLS50	1.0	Copper-Manganese Alloy	$\leq 4.0\text{m}\Omega$
	1.5	Iron-Chromium Aluminium Alloy	$> 4.0\text{m}\Omega$
	2.0		
CLS63	1.0	Copper-Manganese Alloy	$< 3.5\text{m}\Omega$
		Iron-Chromium Aluminium Alloy	$3.5\text{ m}\Omega \leq R \leq 500\text{m}\Omega$
	1.5	Copper-Manganese Alloy	$< 3.5\text{m}\Omega$
		Iron-Chromium Aluminium Alloy	$3.5\text{ m}\Omega \leq R \leq 220\text{m}\Omega$
	2.0	Copper-Manganese Alloy	$< 3.5\text{m}\Omega$
		Iron-Chromium Aluminium Alloy	$3.5\text{ m}\Omega \leq R \leq 100\text{m}\Omega$
		Nickel-Copper Alloy	$101\text{ m}\Omega \leq R \leq 150\text{m}\Omega$
		Nickel-Chromium Aluminium Alloy	$151\text{ m}\Omega \leq R \leq 299\text{m}\Omega$
	3.0	Iron-Chromium Aluminium Alloy	$300\text{ m}\Omega \leq R \leq 500\text{m}\Omega$
		Copper-Manganese Alloy	$\leq 2.5\text{m}\Omega$
		Iron-Chromium Aluminium Alloy	$3\text{m}\Omega \leq R \leq 10\text{m}\Omega$
	CLS27	4.0	Nickel-Copper Alloy
5.0		Copper-Manganese Alloy	$\leq 0.5\text{m}\Omega$
CLS28	3.0	Iron-Chromium Aluminium Alloy	All
	3.5		
	4.0		
CLS45	2.0	Copper-Manganese Alloy	$\leq 3.0\text{m}\Omega$
	3.0	Iron-Chromium Aluminium Alloy	$\geq 4.0\text{m}\Omega$
	5.0		



6. RELIABILITY PERFORMANCE

6.1 Electrical Performance Test

Test Item	Conditions of Test	Test Limits																																									
Temperature Coefficient of Resistance (TCR)	<p>Refer to JIS C 5201-1 4.8</p> $TCR(ppm/^{\circ}C) = \frac{(R2 - R1)}{R1(T2 - T1)} \times 10^6$ <ul style="list-style-type: none"> ● R1: resistance of room temperature ● R2: resistance of 150 °C ● T1: Room temperature ● T2: Temperature at 150 °C 	Refer to Paragraph 3.10																																									
Short Time Overload	<p>Refer to JIS C 5201-1 4.13</p> <p>Applied Overload for 5 seconds and release the load for about 30 minutes, then measure its resistance variance rate. (Overload condition refer to below):</p> <table border="1"> <thead> <tr> <th>Type</th> <th>Power (W)</th> <th># of rated power</th> </tr> </thead> <tbody> <tr> <td rowspan="4">CLS32</td> <td>0.5</td> <td rowspan="4">5 times</td> </tr> <tr> <td>1.0</td> </tr> <tr> <td>1.5</td> </tr> <tr> <td>2.0</td> </tr> <tr> <td>CLS40</td> <td>1.5</td> <td>5 times</td> </tr> <tr> <td rowspan="3">CLS50</td> <td>1.0</td> <td rowspan="3">5 times</td> </tr> <tr> <td>1.5</td> </tr> <tr> <td>2.0</td> </tr> <tr> <td rowspan="4">CLS63</td> <td>1.0</td> <td rowspan="4">5 times</td> </tr> <tr> <td>1.5</td> </tr> <tr> <td>2.0</td> </tr> <tr> <td>3.0</td> </tr> <tr> <td rowspan="2">CLS27</td> <td>4.0</td> <td>5 times</td> </tr> <tr> <td>5.0</td> <td>5 times</td> </tr> <tr> <td rowspan="3">CLS28</td> <td>3.0</td> <td rowspan="3">5 times</td> </tr> <tr> <td>3.5</td> </tr> <tr> <td>4.0</td> </tr> <tr> <td rowspan="3">CLS45S</td> <td>2.0</td> <td rowspan="3">5 times</td> </tr> <tr> <td>3.0</td> </tr> <tr> <td>5.0</td> </tr> <tr> <td>CLS45</td> <td>5.0</td> <td></td> </tr> </tbody> </table>	Type	Power (W)	# of rated power	CLS32	0.5	5 times	1.0	1.5	2.0	CLS40	1.5	5 times	CLS50	1.0	5 times	1.5	2.0	CLS63	1.0	5 times	1.5	2.0	3.0	CLS27	4.0	5 times	5.0	5 times	CLS28	3.0	5 times	3.5	4.0	CLS45S	2.0	5 times	3.0	5.0	CLS45	5.0		<p>≤±0.5%</p> <p>≤±2.0% (CLS45 & CLS45S series)</p>
Type	Power (W)	# of rated power																																									
CLS32	0.5	5 times																																									
	1.0																																										
	1.5																																										
	2.0																																										
CLS40	1.5	5 times																																									
CLS50	1.0	5 times																																									
	1.5																																										
	2.0																																										
CLS63	1.0	5 times																																									
	1.5																																										
	2.0																																										
	3.0																																										
CLS27	4.0	5 times																																									
	5.0	5 times																																									
CLS28	3.0	5 times																																									
	3.5																																										
	4.0																																										
CLS45S	2.0	5 times																																									
	3.0																																										
	5.0																																										
CLS45	5.0																																										
Insulation Resistance	<p>Refer to JIS-C5201-1 4.6</p> <p>Put the resistor in the fixture, add 100 VDC in +,- terminal for 60secs then measured the insulation resistance between electrodes and insulating enclosure or between electrodes and base material.</p>	≥10 ⁹ Ω																																									
Dielectric Withstanding Voltage	<p>Refer to JIS-C5201-1 4.7</p> <p>Applied 500VAC for 1 minute, and Limit surge current 50 mA (max.)</p>	No short or burned on the appearance.																																									

6.2 Mechanical Performance

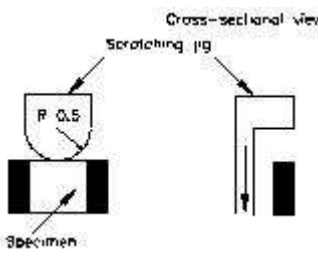
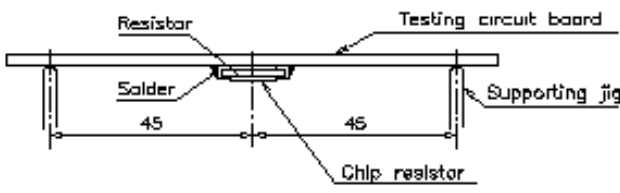
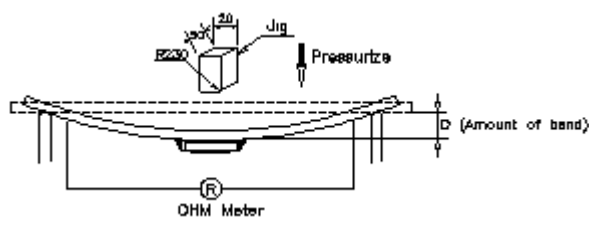
Test Item	Conditions of Test	Test Limits
Resistance to Solder Heat	Refer to JIS-C5201-1 4.18 The tested resistor be immersed 25 mm/sec into molten solder of 260±5°C for 10±1secs. Then the resistor is left in the room for 1 hour, and measured its resistance variance rate.	≤±0.5% No evidence of mechanical damage
Solderability	Refer to JIS-C5201-1 4.17 Add flux into tested resistors, immersion into solder bath in temperature 245±5°C for 3±0.5secs.	Solder coverage over 95%
Core Body Strength	Refer to JIS-C5201-1 4.15 Applied R0.5 test probe at its central part then pushing 5N force on the sample for 10 sec.	≤±0.5% No evidence of mechanical damage
Joint Strength of Solder	<p>Refer to JIS-C5201-1 4.32</p> <p>Preconditioning Put tested resistor in the apparatus of PCT, at a temperature of 105°C, humidity of 100% RH, and pressure of 1.22×10⁵ Pa for a duration of 4 hours. Then after left the specimen in a temperature for 2 hours or more.</p> <p>Test method:</p> <p>©Test item 1 (Adhesion): A static load using a R0.5 scratch tool shall be applied on the core of the component and in the direction of the arrow and held for 10 seconds and under load measured its resistance variance rate. Load:17.7N</p> 	<p>Test item 1: (1). ≤±0.5% (2). No evidence of mechanical damage. No terminal peeling off.</p> <p>Test item 2: (1). ≤±0.5% (2). No evidence of mechanical damage. No terminal peeling off and core body cracked.</p>
	<p>Refer to JIS-C5201-1 4.33</p> <p>©Test item 2 (Bending Strength): Solder tested resistor on to PC board add force in the middle down, and under load measured its resistance variance rate. D:2mm</p> 	
		

METAL ALLOY LOW-RESISTANCE CHIP RESISTOR

CLS Series

DS-ENG-007

Page: 18 of 29

Test Item	Conditions of Test	Test Limits
Resistance to solvent	Refer to JIS-C5201-1 4.29 The tested resistor be immersed into isopropyl alcohol of 20~25°C for 60secs, then the resistor is left in the room for 48 hrs.	≤±0.5%
		No evidence of mechanical damage
Vibration	Refer to JIS-C5201-1 4.22 The resistor shall be mounted by its terminal leads to the supporting terminals on the solid table. The entire frequency range :from 10 Hz to 55 Hz and return to 10 Hz, shall be transferred in 1 min. Amplitude : 1.5mm This motion shall be applied for a period of 4 hours in each 3 mutually perpendicular directions (a total of 12hrs)	≤±0.5%
		No evidence of mechanical damage

6.3 Environmental Test

Test Item	Conditions of Test	Test Limits
Low Temperature Exposure (Storage)	Refer to JIS-C5201-1 4.23.4 Put the tested resistor in chamber under temperature - 55±2°C for 1,000 hours. Then leaving the tested resistor in room temperature for 60 minutes, and measure its resistance variance rate.	≤±0.5%
		≤±1% for 2512(1W) 301~500MΩ ≤±1% for 2512(2W) 101~500mΩ ≤±1% for 2512(3W) 50~150mΩ No evidence of mechanical damage
High Temperature Exposure (Storage)	Refer to JIS-C5201-1 4.23.2 Put tested resistor in chamber under temperature 170±5°C for 1,000 hours. Then leaving the tested resistor in room temperature for 60 minutes , and measure its resistance variance rate.	≤±1.0%
		No evidence of mechanical damage
Temperature Cycling (Rapid Temperature Change)	Refer to JESD22-A104 Put the tested resistor in the chamber under the temperature cycling which shown in the following table shall be repeated 1,000 times consecutively. Then leaving the tested resistor in the room temperature for 60 minutes, and measure its resistance variance rate.	≤±0.5%
		≤±1% for 2512(1W) 301~500MΩ ≤±1% for 2512(2W) 101~500mΩ ≤±1% for 2512(3W) 50~150mΩ No evidence of mechanical damage
Moisture Resistance (Climatic Sequence)	Refer to MIL-STD 202 Method 106 Put the tested resistor in chamber and subject to 10 cycles of damp heat and without power. Each one of which consists of the steps 1 to 7 (Figure 1). Then leaving the tested resistor in room temperature for 24 hr, and measure its resistance variance rate.	≤±0.5%
		≤±1% for 2512(1W) 301~500MΩ ≤±1% for 2512(2W) 101~500mΩ ≤±1% for 2512(3W) 50~150mΩ No evidence of mechanical damage



Product Specification

Towards Excellence in Quality, Service & Innovation

METAL ALLOY LOW-RESISTANCE CHIP RESISTOR

CLS Series

DS-ENG-007

Page: 19 of 29

Test Item	Conditions of Test	Test Limits										
Bias Humidity	<p>Refer to JIS-C5201-1 4.24 Put the tested resistor in chamber under 85± 5°C and 85± 5%RH with 10% bias and load the rated current for 90 minutes on, 30 minutes off, total 1,000 hours. Then leaving the tested resistor in room temperature for 60 minutes, and measure its resistance variance rate.</p>	<p>≤±0.5% ≤±1% for 2512(1W) 301~500MΩ ≤±1% for 2512(2W) 101~500mΩ ≤±1% for 2512(3W) 50~150mΩ No evidence of mechanical damage</p>										
Whisker Test	<p>By JESD Standard NO.22A121 class 2. ©Test item (Thermal Shock test):</p> <table border="1" style="margin-left: 20px;"> <thead> <tr> <th colspan="2">Testing Condition</th> </tr> </thead> <tbody> <tr> <td>Minimum storage temperature</td> <td>-55+0/-10°C</td> </tr> <tr> <td>Maximum storage temperature</td> <td>85+10/-0°C</td> </tr> <tr> <td>Temperature-retaining time</td> <td>10 min.</td> </tr> <tr> <td>Number of temperature cycles</td> <td>1,500</td> </tr> </tbody> </table> <p>©Inspection: Inspect for whisker formation on specimens that underwent the acceleration test specified in sub-clause 4.2, with a magnifier (stereo microscope) of about 40 or higher magnification. If judgment is hard in this method, use a scanning electron microscope (SEM) of about 1,000 or higher magnification.</p>	Testing Condition		Minimum storage temperature	-55+0/-10°C	Maximum storage temperature	85+10/-0°C	Temperature-retaining time	10 min.	Number of temperature cycles	1,500	<p>Max. 50µm</p>
Testing Condition												
Minimum storage temperature	-55+0/-10°C											
Maximum storage temperature	85+10/-0°C											
Temperature-retaining time	10 min.											
Number of temperature cycles	1,500											

6.4 Operational Life Endurance

Test Item	Conditions of Test	Test Limits
Load Life	<p>Refer to JIS-C5201-1 4.25 Put the tested resistor in chamber under temperature 70± 2°C and load the rated current for 90 minutes on 30 minutes off, total 1000 hours. Then leaving the tested resistor in room temperature for 60 minutes, and measure its resistance variance rate.</p>	<p>≤±1.0% ≤±2.0% (CLS45 & CLS45S Series) No evidence of mechanical damage</p>



Product Specification

Towards Excellence in Quality, Service & Innovation

METAL ALLOY LOW-RESISTANCE CHIP RESISTOR

CLS Series

DS-ENG-007

Page: 20 of 29

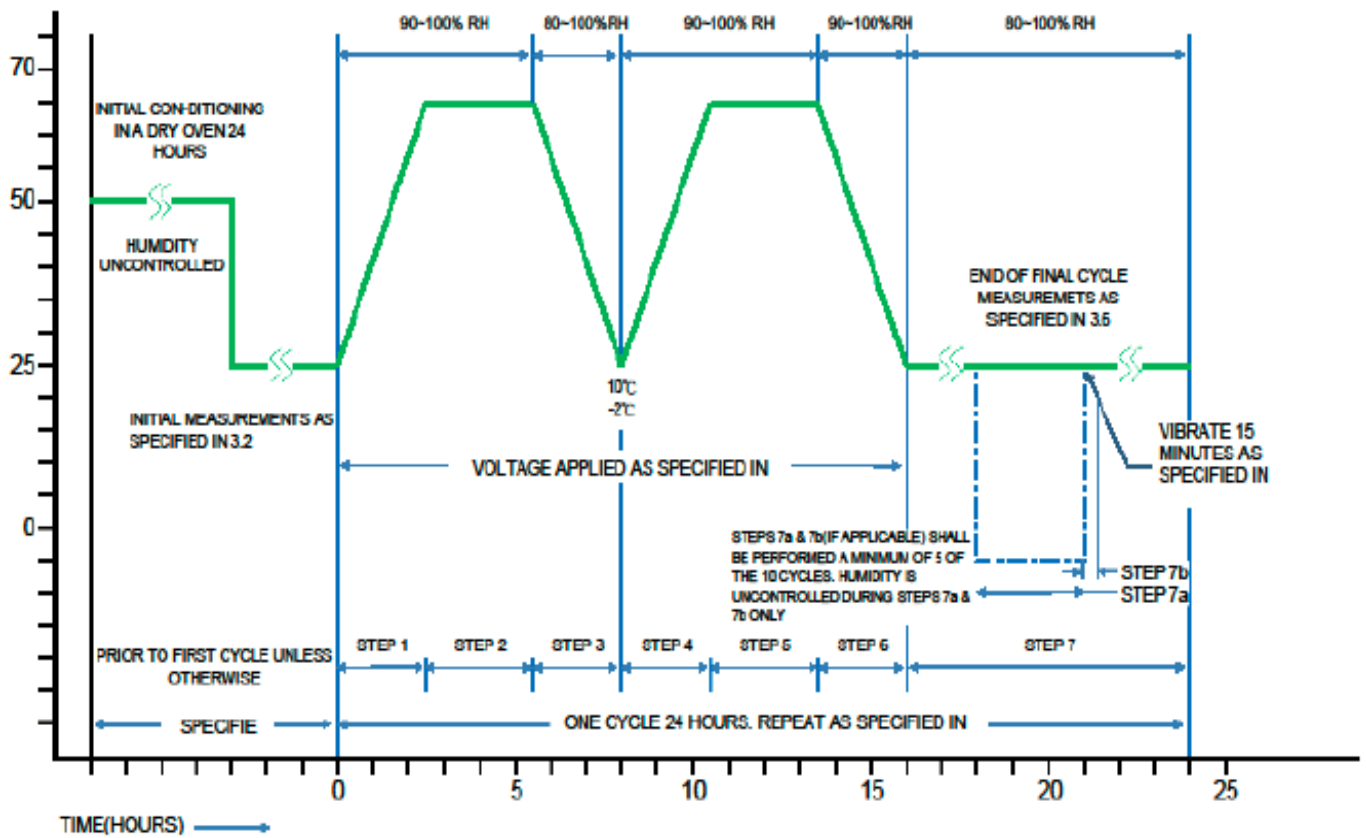

Product Specification

Towards Excellence in *Quality, Service & Innovation*

6.5 Soldering Profile

Technical Notes: This is for recommendation, customer please perform adjustment according to actual application.

6.5.1 Surface-mount components are tested for solderability at temperature of 245°C for 3 seconds. Typical examples of soldering processes that provide reliable joint without any damage are giving as below:

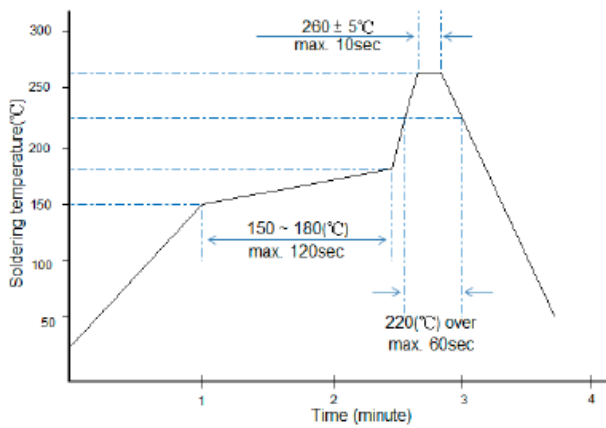

Recommended IR Reflow Soldering profile
MEET J-STD-020D

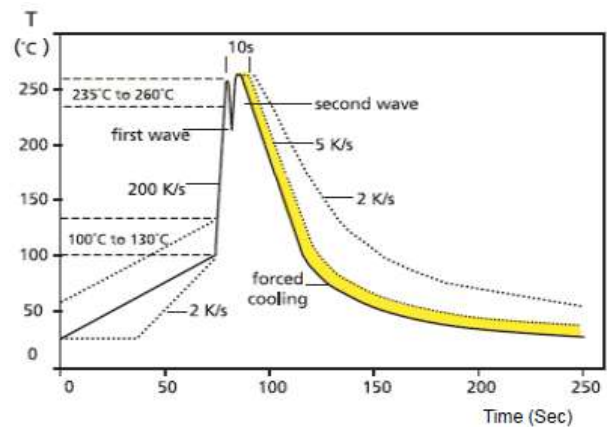

Recommended Wave Soldering Profile
Typical values (solid line)
Process limits (dotted line)

6.5.2 Soldering Iron: Temperature 350°C±10°C, dwell time shall be less than 3 sec.

7. TAPING

7.1 Structure of Taping

Embossed Plastic Carrier

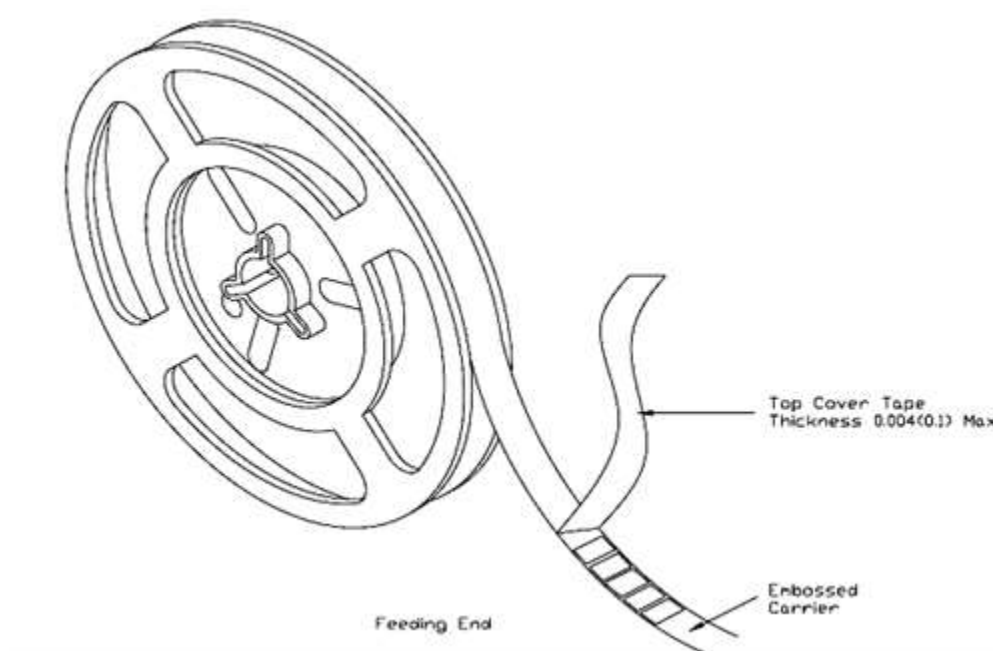

7.2 Tape dimension

7.2.1 Tape Dimension of Plastic Embossed Carrier System

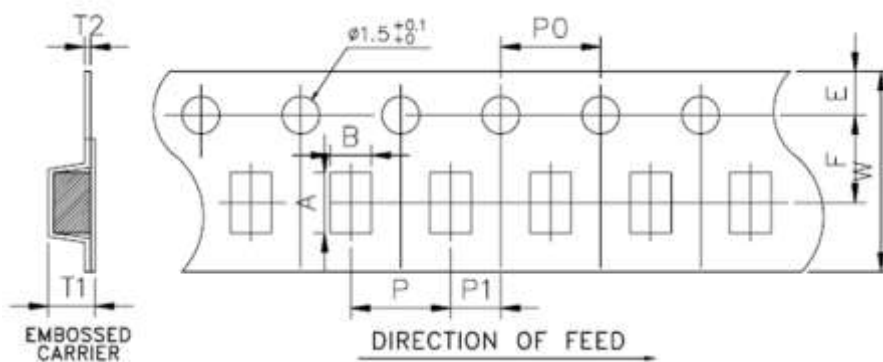

METAL ALLOY LOW-RESISTANCE CHIP RESISTOR

CLS Series

DS-ENG-007

Page: 23 of 29

Dimension of Embossed Plastic Carrier System

Unit: mm

Item \ DIM	A	B	W	E	F	T1	T2	P	P0	10*P0	P1
CLS32 (0.5~0.6mΩ)	3.50±0.10	1.90±0.10	8.0±0.15	1.75±0.10	3.5±0.10	1.27±0.10	0.23±0.10	4.0±0.10	4.0±0.10	40.0±0.20	2.0±0.10
CLS32 (≥1.0mΩ)	3.48±0.10	1.83±0.10	8.0±0.15	1.75±0.10	3.5±0.10	1.10±0.10	0.20±0.05	4.0±0.10	4.0±0.10	40.0±0.20	2.0±0.10
CLS40	3.5±0.1	3.0±0.1	8.0±0.2	1.75±0.1	3.5±0.1	1.10±0.1	0.22±0.05	4.0±0.1	4.0±0.1	40.0±0.2	2.0±0.1
CLS50	5.45±0.10	2.90±0.10	12.0±0.15	1.75±0.10	5.5±0.10	1.33±0.10	0.23±0.05	4.0±0.10	4.0±0.10	40.0±0.20	2.0±0.10
CLS63 (0.3mΩ)	6.74±0.10	3.50±0.10	12.0±0.15	1.75±0.10	5.5±0.10	1.60±0.10	0.24±0.05	8.0±0.10	4.0±0.10	40.0±0.20	2.0±0.10
CLS63	6.75±0.10	3.50±0.10	12.0±0.15	1.75±0.10	5.5±0.10	1.30±0.10	0.20±0.05	4.0±0.10	4.0±0.10	40.0±0.20	2.0±0.10
CLS27	7.15±0.10	6.75±0.10	12.0±0.15	1.75±0.10	5.5±0.10	1.95±0.10	0.25±0.05	8.0±0.10	4.0±0.10	40.0±0.20	2.0±0.10
CLS28	7.15±0.10	7.70±0.10	12.0±0.15	1.75±0.10	5.5±0.10	1.45±0.10	0.25±0.05	12.0±0.10	4.0±0.10	40.0±0.20	2.0±0.10
CLS45	11.80±0.10	7.20±0.10	24.0±0.15	1.75±0.10	11.5±0.10	2.00±0.10	0.30±0.10	12.0±0.10	4.0±0.10	40.0±0.20	2.0±0.10
CLS45S	11.80±0.10	7.20±0.10	24.0±0.15	1.75±0.10	11.5±0.10	2.00±0.10	0.30±0.10	12.0±0.10	4.0±0.10	40.0±0.20	2.0±0.10

7.3 Packaging

7.3.1 Taping

7.3.1.1 Quantity - Tape and Reels

Type	Tape Width	Packaging Quantity(pcs/reel)		
		Emboss Plastic Type		
		4 mm Pitch	8 mm Pitch	12 mm Pitch
CLS32(0.5~0.6mΩ)	8 mm	2,000 pcs	---	---
CLS32(≥1.0mΩ)		4,000 pcs	---	---
CLS40	8mm	4,000 pcs	---	---
CLS50	12 mm	2,000/4,000 pcs	---	---
CLS63(0.3mΩ)		---	1,000 pcs	---
CLS63		4,000 pcs	---	---
CLS27		---	1,000 pcs	---
CLS28		---	---	1,000 pcs
CLS45 CLS45S		24 mm	---	---



Product Specification

Towards Excellence in Quality, Service & Innovation

7.3.2 Identification

Production label that indicates the 10 digits lot number, product type, resistance value and tolerance shall be pasted on the surface of each reel.

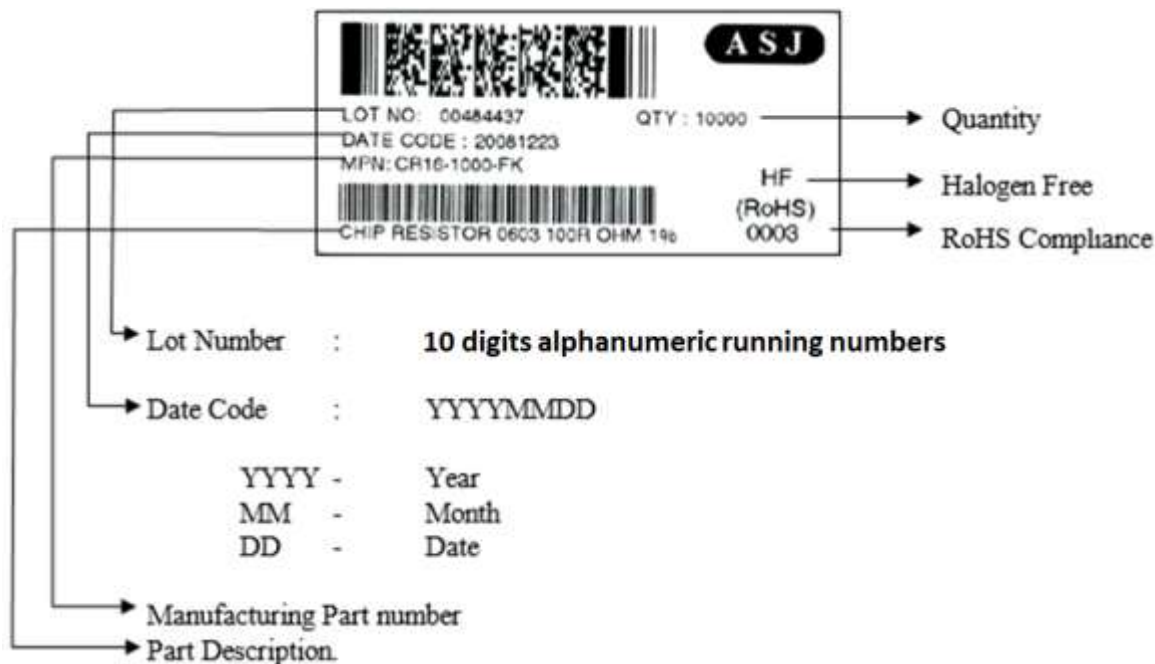

7.3.3 Reel Dimension

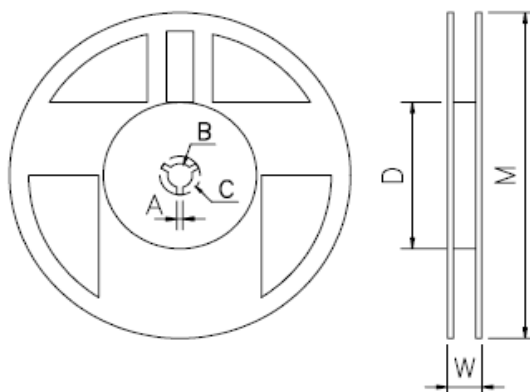

Unit: mm

Reel Type / Tape	W	M	A	B	C	D
7" reel for 8 mm tape	9.0 ± 0.5	178 ± 2.0	2.0 ± 0.5	13.5 ± 0.5	21.0 ± 0.5	60.0 ± 1.0
7" reel for 12 mm tape	13.8 ± 0.5					80.0 ± 1.0
7" reel for 24 mm tape	25.0 ± 1.0			60.0 ± 1.0		

8. RECOMMENDED LAND PATTERN

When a component is soldered, the resistance after soldering changes slightly depending on the size of the soldering area and the amount of soldering. When designing a circuit, it is necessary to consider the effect of a decrease or increase in its resistance.

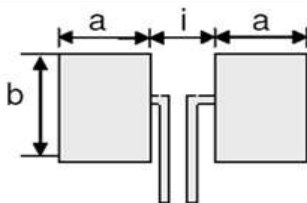

Type	Maximum Power Rating (Watts)	Resistance Range (mΩ)	Dimensions - in millimeters			
			a	b	i	
CLS32	0.5 & 1 & 1.5 & 2	0.5 ~ 0.6	1.65	2.18	0.90	
		1 ~ 50	1.60		1.00	
CLS40	1.5	2 ~ 10	1.25	2.92	1.70	
CLS50	1 & 1.5 & 2	0.5 ~ 3	2.89	2.92	1.22	
		3.1 ~ 100	2.29		2.41	
CLS63	1	0.3 ~ 0.7	3.05	3.68	1.27	
		0.8 ~ 4				2.19
		0.75	2.19		3.00	
		4.1 ~ 300	2.11		3.18	
		301 ~ 500	2.11		3.18	
	1.5	0.3 ~ 0.7	3.05		1.27	
		0.8 ~ 4			2.19	
		0.75	2.19			3.00
		4.1 ~ 220	2.11			3.18
	2	0.3 ~ 0.7	3.05			1.27
		0.8 ~ 4			2.19	
		0.75	2.19			3.00
		4.1 ~ 75	2.11			3.18
		80 ~ 500	2.11			3.18
	3	0.3 ~ 0.5	3.05			1.27
		0.6 ~ 2.9			2.19	
4.1 ~ 10		2.19	3.00			
3 ~ 4		2.79	1.80			
50~150		2.11	3.18			
CLS27	4 & 5	0.2 ~ 3	3.18	6.86		1.32
CLS28	3	4 ~ 200	2.75	7.82	3.51	
	3.5	4 ~ 100				
	4	4 ~ 80				
CLS45S	2	0.5 ~ 5	5.80	8.74	3.51	
		5.1 ~ 200	4.15		6.81	
	3	0.5 ~ 5	5.80		3.51	
		5.1 ~ 27	4.15		6.81	
	5	0.5 ~ 5	5.80		3.51	
		5.1 ~ 7.5	4.15		6.81	
CLS45	5	0.5 ~ 5	5.80	8.74	3.51	
		5.1 ~ 200	4.15		6.81	

8.1 Recommended Dispensing Method

8.1.1 The structure of ASJ metal alloy resistor that both side of main body would be thinner due to process factor (as the photo below).

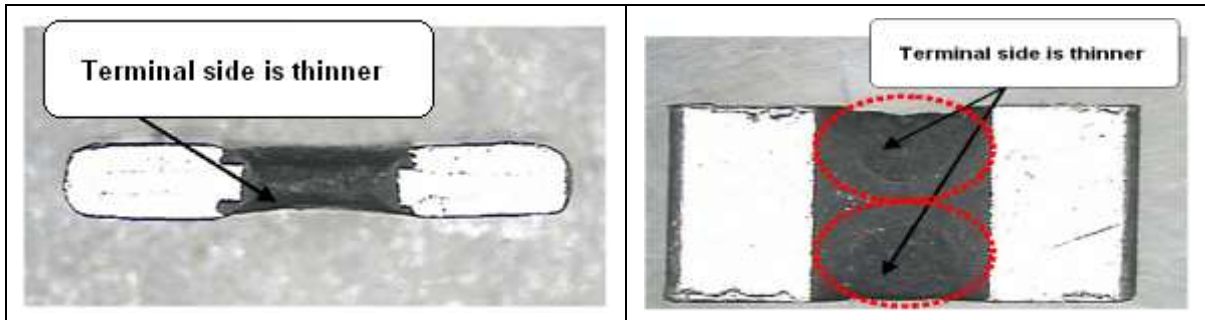

8.1.2 When customer performs wave solder process shall take note on the dispensing gap. If the gap between two dispensing is over, the red-glue will not adhesive the resistor body and be dropped out (as photo 1). Therefore, we suggest customer to narrow down the dispenser gap (as photo 2), or dispenser on the body center (as photo 3)

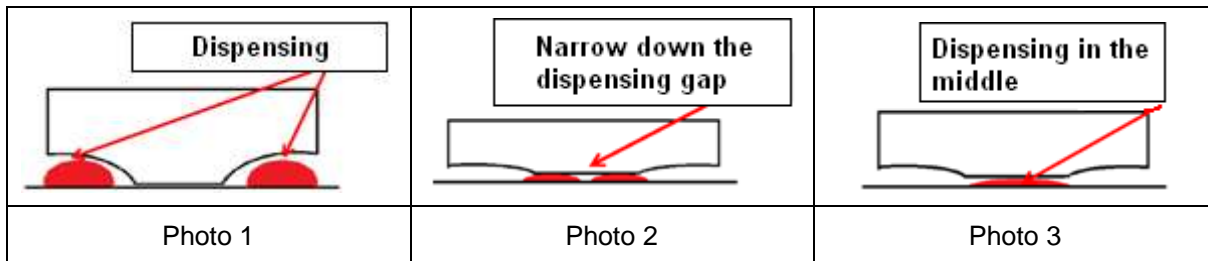



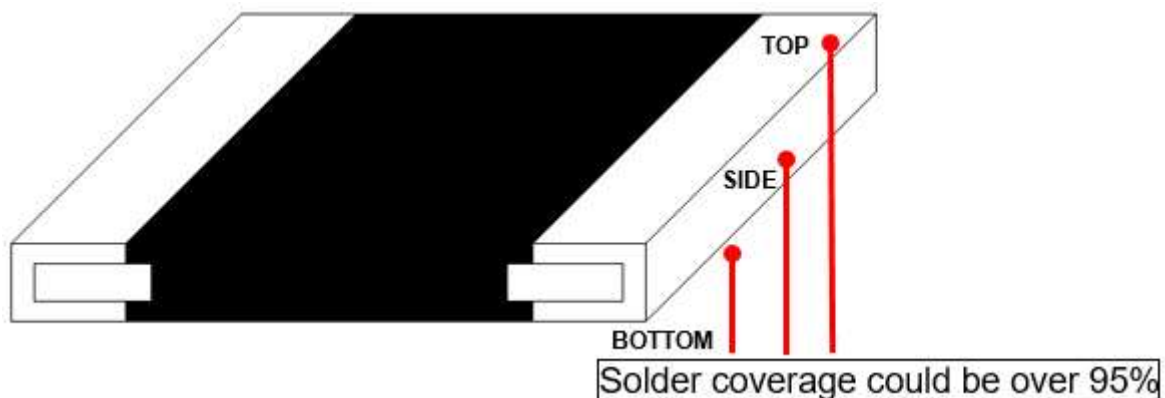

8.1.3 Product Warranted solder area

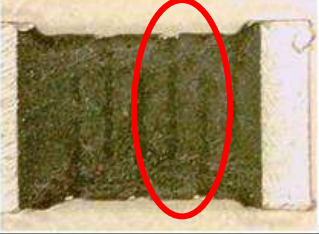

8.1.4 Appearance

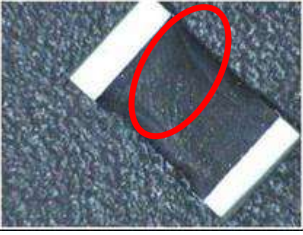
The metal alloy need more punch for product, appearance of the product are listed below :

Illustration of qualified protective layer	Illustration of abnormal protective layer
<p>a. Punch mark is allowed but raw material (substrate) cannot exposed.</p>  <p>b. Without cracks are found on the protective layer when looking at product under naked eyes at a distance of 30 cm.</p>  <p>c. Dent is allowed at the joining point of protective layer and electrode tip.</p>  <p>d. Bulging appearance (bulging degree should not exceed height of electrode tip) is allowed at the joining point of protective layer and electrode tip.</p> 	<p>a. Substance is not to have any fractures that would expose itself.</p> 

METAL ALLOY LOW-RESISTANCE CHIP RESISTOR

CLS Series

DS-ENG-007

Page: 28 of 29

9. REVISION HISTORY

REVISION	DATE	CHANGE NOTIFICATION	DESCRIPTION
Version.1	13.02.2015		Initial Release
Version.2	23.07.2015		TCR spec update
Version.3	06.09.2016		Update clause 2, Part Numbering System Update clause 3.1.1, Resistor Rated Power Table Update clause 3.1.2, Power Derating Curve Update clause 3.10, Resistance, Resistance Tolerance & TCR table Update clause 4.1, Numeric Numbering table Update clause 5, Dimension table Update clause 6.1, Electrical Performance test Update clause 6.2, Mechanical Performance test Update clause 6.3, Environmental test Update clause 6.4, Operation Life Endurance test Update clause 7.2.1, Tape dimension Table Update clause 7.3.1.1, Tape and reels table Update clause 8, Land Pattern table
Version.4	14.10.2016		Typo error in clause 2
Version.5	08.08.2017		Update clause 3.1.1 Resistor Rated Power Update clause 3.10 Resistance, Resistance Tolerance and Temperature Coefficient of Resistance Update clause 5 Dimension
Version.6	05.12.2017	Refer to ECN: G2017E045	Change marking of CLS63 4mΩ and below from 4 digit to 3 digit
Version.7	03.01.2019		Datasheet Update
Version.8	15.01.2019		Update clause 3.10 table Update clause 5 table Update clause 7.2.1 table Update clause 7.3.1.1 table Update clause 8 table
Version.9	05.03.2019		Update clause 2 Part Numbering System Update clause 3.1.1 table Update clause 3.10 table Update clause 5 dimension
Version.10	04.09.2019		Revise clause 3.9 Revise clause 5 dimension
Version.11	19.11.2019		Revise clause 3.10 TCR table Revise clause 5 dimension Add clause 6.5.2 Iron temperature Revise clause 8 dimension Add clause 8.1.4 Appearance
Version.12	24.09.2020		Add product CLS40 Revise clause 2 Part Numbering System Revise clause 3.5 Revise clause 3.10 TCR table Add clause 4.2.2.1 CLS40 marking Revise clause 4.3 Marking Style Revise clause 5 Dimension table Revise clause 5.1 Material of alloy table Revise clause 6.1 item Short time overload Revise clause 7.2.1 Tape dimension table Revise clause 7.3.1.1 tape and reel qty table Revise clause 8 Land Pattern dimension table



Product Specification

Towards Excellence in **Quality, Service & Innovation**

METAL ALLOY LOW-RESISTANCE CHIP RESISTOR

CLS Series

DS-ENG-007

Page: 29 of 29

REVISION	DATE	CHANGE NOTIFICATION	DESCRIPTION
Version.13	07.03.2023		Revise clause 3.7 Product Assurance. Revise clause 3.9 table, Resistance Range.
Version 14	16.05.2023		Add CLS63 1W 301~500mΩ, 2W 80~100mΩ and 2W 300~500mΩ related specifications and Resistance Range 1~6mΩ for resistance tolerance ±0.5%. Revise clause 3.9 Resistance, Resistance Tolerance and Temperature Coefficient of Resistance Revise clause 5 Dimension Revise clause 6.3 Environmental Test Revise clause 8 Recommended Land Pattern Add clause 4.2.5 CLS63 Series 2 Watts, 80 ~ 100 mΩ (4-digits marking)
Version 15	07.07.2023		Revise clause 4.2.4.2 > 4.0mΩ (4-digits marking) Revise clause 5 Dimension CLS63 (2W) 300mR~500mR schematic diagram Revise clause 5 table, CLS63 1W, 1.5W resistance range
Version 16	14.08.2023		Revise clause 3.1.1 Resistor Rated Power table Revise clause 3.9 table Revise clause 8 Recommended Land Pattern table
Version 17	07.12.2023		Revise clause 3.9 table. Revise clause 5 Dimension drawing and table. Revise clause 5.1 Material of Alloy table. Revise clause 7.3.2 Identification. Revise clause 8 Recommended Land Pattern table. Revise clause 8.1.4 Appearance.



Product Specification

Towards Excellence in **Quality, Service & Innovation**