

# YESC KAIZEN CONNECTORS

SUPPLEMENT  
TO YESC CATALOG

GO

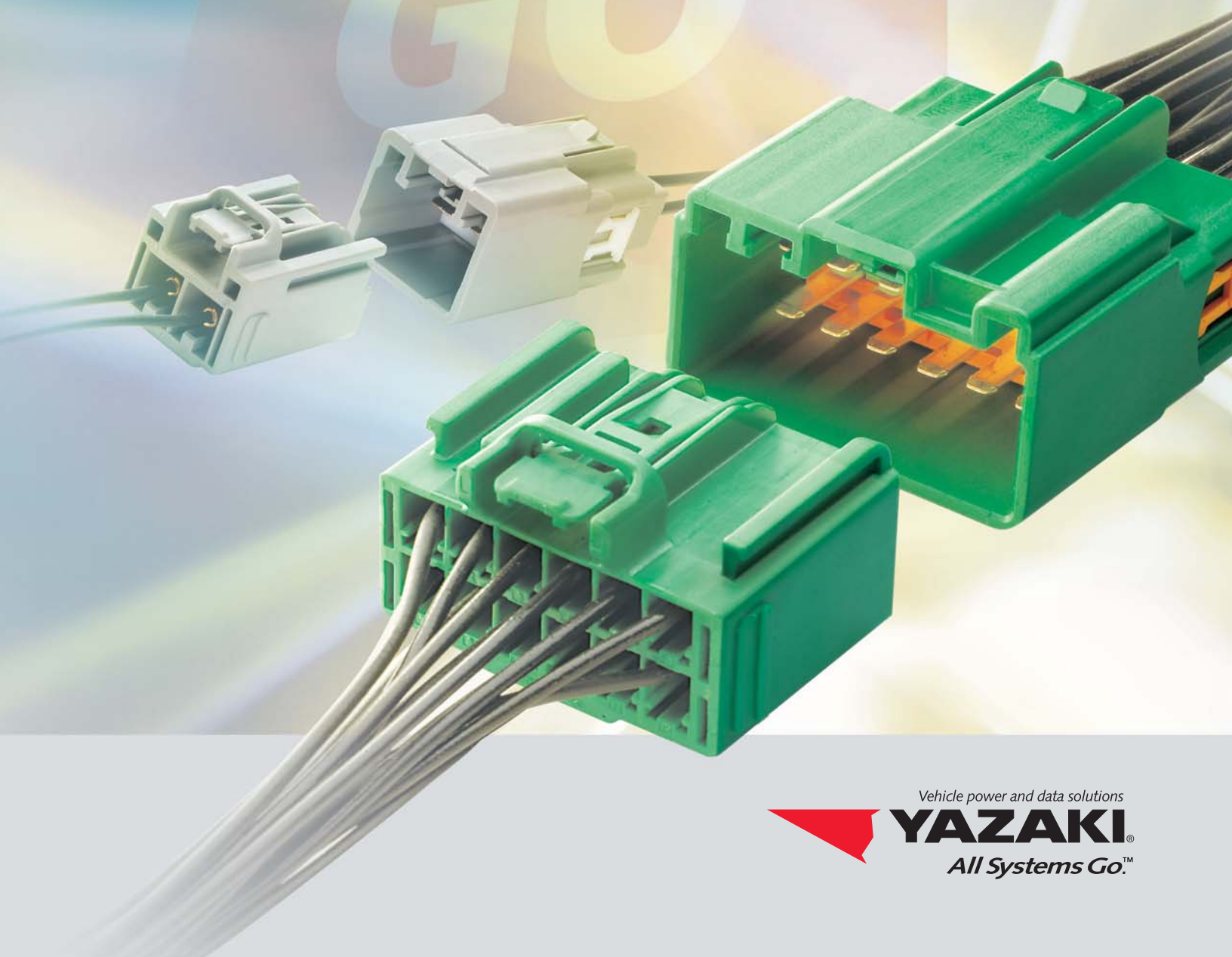

Vehicle power and data solutions

**YAZAKI**  
All Systems Go.™

# *THE* YESC KAIZEN CONNECTION

*YESC KAIZEN stands for continuous improvement – the heart of a tradition that's helped make Yazaki the world's largest supplier of vehicle power and data networks, and related components. Now we've extended that tradition, combining Yazaki quality standards with highly cost-efficient engineering, to create the new YESC KAIZEN connector series. The latest addition to the Yazaki Engineering Standard Connectors (YESC) line, YESC KAIZEN connectors help engineers meet the aggressive performance, cost, and serviceability requirements of today's more capable, feature-rich vehicles. When it comes to continuous improvement in connectors, look to YESC KAIZEN from Yazaki.*



# YESC KAIZEN

## CONNECTORS

### CONTENTS

	<b>PAGE</b>	
0.64 x 0.64 UNSEALED	1 – 8	<i>0.64 SERIES</i>
0.64 x 0.64 SEALED	9 – 12	
1.5 x 0.8 UNSEALED	13 – 20	<i>1.5 SERIES</i>
2.8 x 0.8 UNSEALED	21 – 26	<i>2.8 SERIES</i>
6.3 x 0.8 UNSEALED	27 – 30	<i>6.3 SERIES</i>
9.5 x 1.2 SEALED	31 – 36	<i>9.5 SERIES</i>
HYBRID	37 – 42	<i>HYBRID SERIES</i>
HEADER	43 – 50	<i>HEADER SERIES</i>
TERMINAL REMOVAL	51 – 54	<i>TERMINAL REMOVAL</i>
INDEX	55-56	<i>INDEX</i>
PART NUMBERING METHODOLOGY	57	

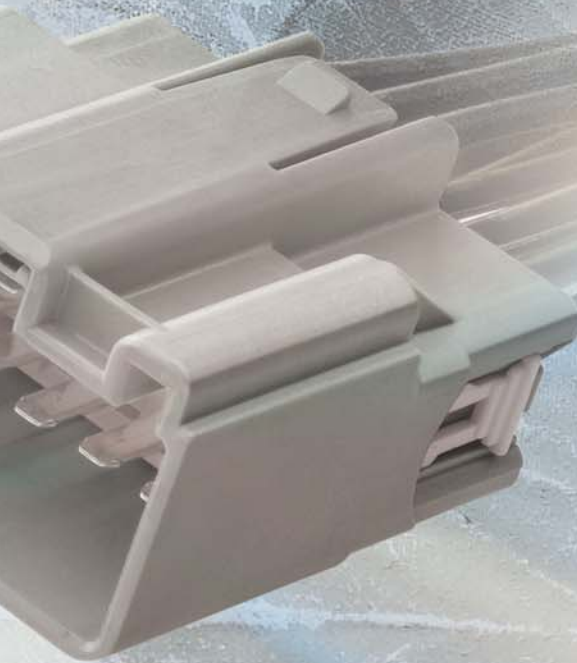

# YESC KAIZEN

## CONNECTORS

### SYSTEM FEATURES

- **Popular-Size Sealed and Unsealed Connectors Available Immediately**

The YESC KAIZEN connector series includes a full range of sealed and unsealed connector styles in stock, available for immediate delivery worldwide – for virtually any vehicle application.

- **USCAR / ISO Standard Compliant**

Terminal blade sizes meet USCAR and ISO standards (0.64 x 0.64, 1.5 x 0.8, 2.8 x 0.8, 6.3 x 0.8).

- **Terminal Position Assurance Device**

Yazaki's Terminal Position Assurance Device is available front-loaded and preset to the connector housing.

- **Wire Gauges for Every Application**

The YESC KAIZEN connector series is compatible with a wide range of both US (AWG) and metric (mm<sup>2</sup>) wire sizes.

- **Interchangeable With YESC**

All YESC KAIZEN connectors (except for the 0.64 series) have the same footprint as, and are fully interchangeable with, equivalent standard YESC.

- **Designed to Perform**

All YESC KAIZEN connectors are designed to meet USCAR performance specifications.

## SEALED

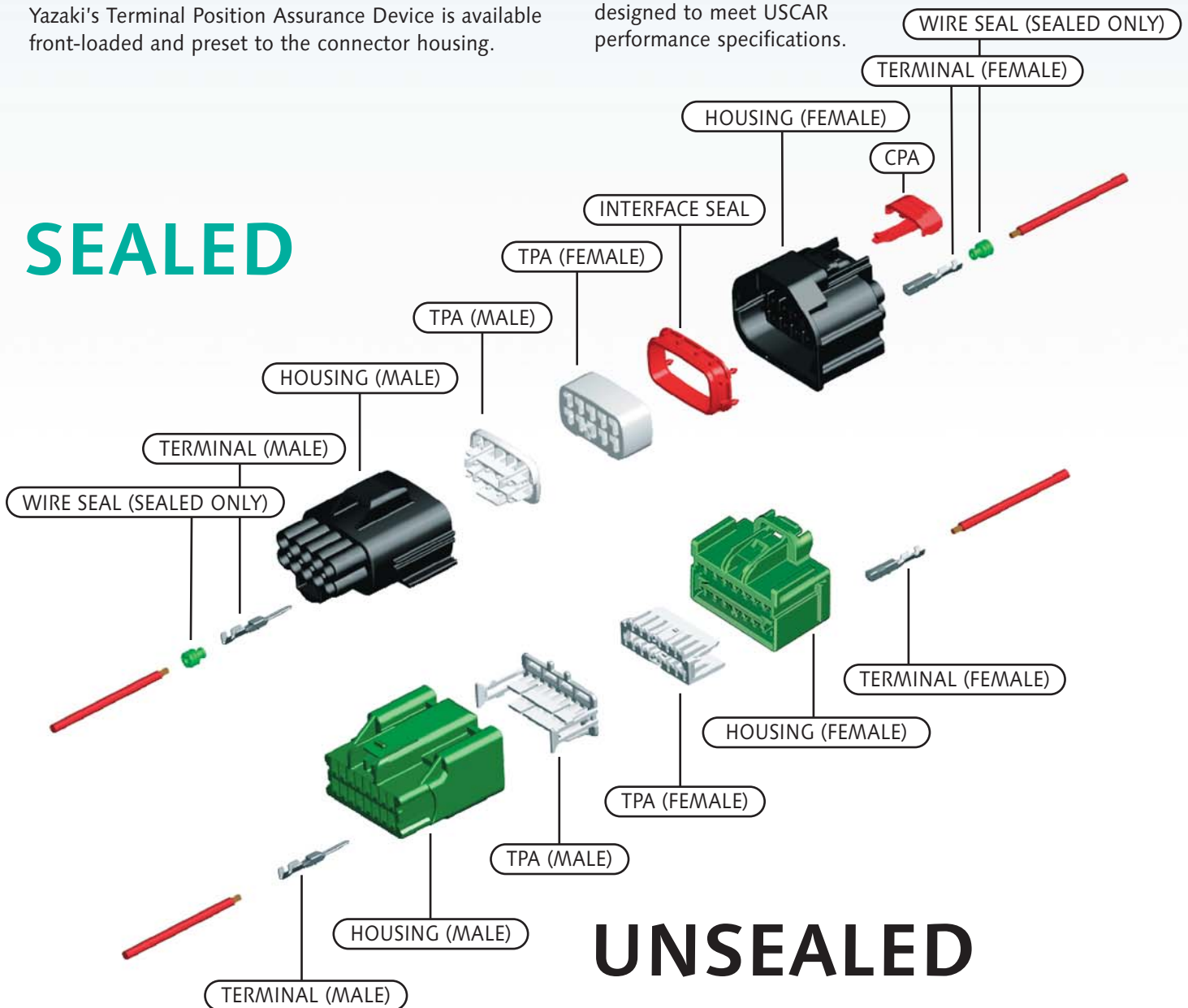

## UNSEALED

YESC KAIZEN

CONNECTORS

# Hybrid

## SERIES



HYBRID  
SERIES

SUPPLEMENT TO YESC CATALOG

## Specifications

Material	Connector	PBT+GF
	Male Terminal	Copper Alloy (Sn/Au Plate)
	Female Terminal	Copper Alloy (Sn/Au Plate)
Operating Temperature Range		-40°C ~100°C (120°C max temp.) (USCAR Class II)
Operating Temperature Range		-40°C ~125°C (145°C max temp.) (USCAR Class III)
Current Capacity		(See Chart)
Voltage Drop		10mΩ max (Term./Term.) (Crimp-to-Crimp)
Isolation Resistance		500VDC, 20MΩ min
Dielectric Resistance		1000VAC (1 minute)
Applicable Wire Size		See Specific Connector Section
Terminal-to-Connector Retention Force		See Specific Connector Section
Connector-to-Connector Retention Force		See Specific Connector Section

## Terminal

UNIT: mm

Description	YESC Part Number	YESC KAIZEN Part Number	Plating	Applicable Wire Size			
				Europe (mm <sup>2</sup> )	U.S.A. (AWG)	Japan (mm <sup>2</sup> )	
Male Terminal	1.5mm	7114-4100-02/-08	—	Sn/Au	0.35 ~ 0.5	22 ~ 20	0.3 ~ 0.5
		7114-4101-02/-08	—	Sn/Au	0.75 ~ 1.0	18 ~ 16	0.85 ~ 1.25
	2.8mm	7114-4110-02	—	Sn	0.35 ~ 0.5	22 ~ 20	0.3 ~ 0.5
		7114-4111-02	—	Sn	0.75 ~ 1.0	18 ~ 16	0.85 ~ 1.25
		7114-4112-02	—	Sn	1.5 ~ 2.5	14	2.0
	6.3mm	7114-4120-02	—	Sn	0.5 ~ 1.0	20 ~ 16	0.5 ~ 1.25
		7114-4121-02	—	Sn	1.5 ~ 2.5	14	2.0
		7114-4122-02	—	Sn	4.0	12	3.0
	Female Terminal	1.5mm	7116-4100-02	7116-4780-02	Sn	0.35 ~ 0.5	22 ~ 20
7116-4100-08			—	Au	0.35 ~ 0.5	22 ~ 20	0.3 ~ 0.5
7116-4101-02			7116-4781-02	Sn	0.75 ~ 1.0	18 ~ 16	0.85 ~ 1.25
7116-4101-08			—	Au	0.75 ~ 1.0	18 ~ 16	0.85 ~ 1.25
2.8mm		7116-4110-02	7116-4270-02	Sn	0.35 ~ 0.5	22 ~ 20	0.3 ~ 0.5
		7116-4111-02	7116-4271-02	Sn	0.75 ~ 1.0	18 ~ 16	0.85 ~ 1.25
		7116-4112-02	7116-4272-02	Sn	1.5 ~ 2.5	14	2.0
6.3mm		7116-4120-02	—	Sn	0.5 ~ 1.0	20 ~ 16	0.5 ~ 1.25
		7116-4121-02	—	Sn	1.5 ~ 2.5	14	2.0
	7116-4122-02	—	Sn	4.0	12	3.0	

## Retainer Clip/Bracket Dimensions

UNIT: mm

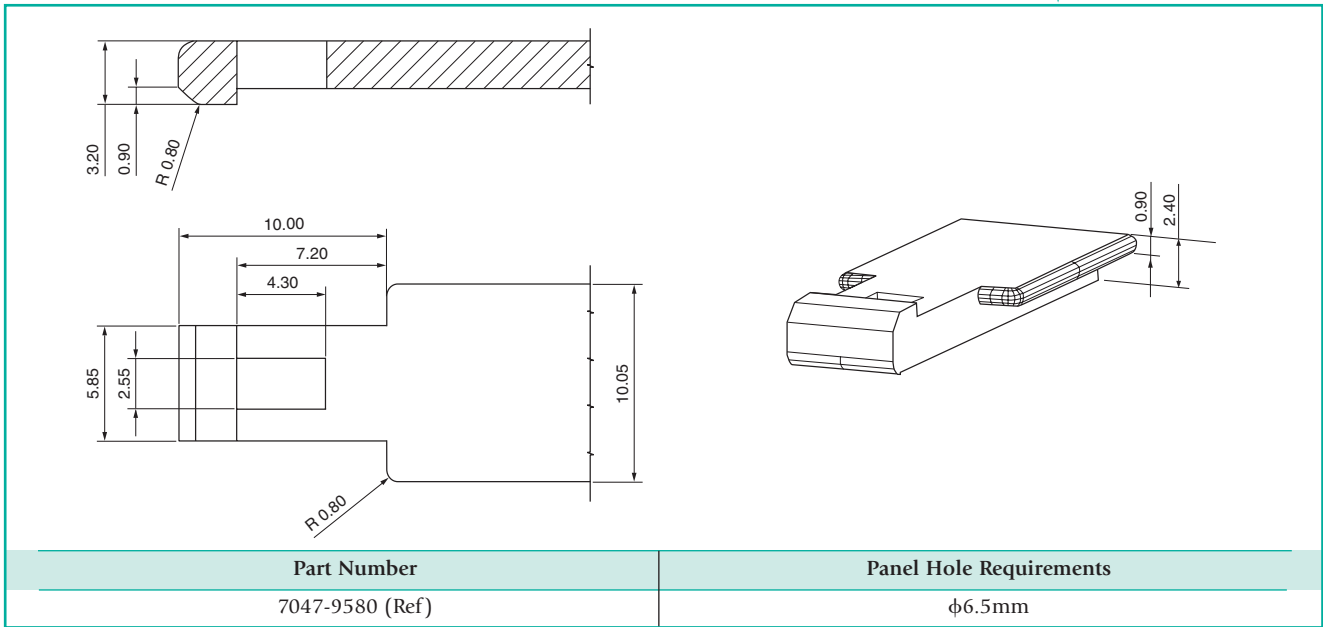

## Part Number Summary Chart

Part Name	YESC Male Part Number	YESC KAIZEN Male Part Number	YESC Female Part Number	YESC KAIZEN Female Part Number	
Terminal	1.5mm	7114-4100-02	—	7116-4100-02	7116-4780-02
		7114-4100-08	—	7116-4100-08	—
		7114-4101-02	—	7116-4101-02	7116-4781-02
		7114-4101-08	—	7116-4101-08	—
	2.8mm	7114-4110-02	—	7116-4110-02	7116-4270-02
		7114-4111-01	—	7116-4111-02	7116-4271-02
		7114-4112-02	—	7116-4112-02	7116-4272-02
	6.3mm	7114-4120-02	—	7116-4120-02	—
		7114-4121-02	—	7116-4121-02	—
		7114-4122-02	—	7116-4122-02	—
	Applicable Clip	7047-9580 (Ref)	—	—	—

## Part Number Summary Chart (cont.)

Pole	Polarity	Color/ Description	YESC Male Part Number	YESC KAIZEN Male Part Number	YESC Female Part Number	YESC KAIZEN Female Part Number
8	A	Light Grey 6 x1.5, 2x2.8	7282-5620-40	7282-6448-40	7283-5620-40	7283-6448-40
10	A	Light Grey 6x1.5, 4x2.8	7282-5621-40	7282-6459-40	7283-5621-40	7283-6459-40
13	A	Light Grey 11x2.8,2x6.3	7282-5625-40	7282-6569-40	7283-5625-40	7283-6569-40
14	A	Light Grey 10x1.5, 4x2.8	7282-5622-40	7282-6447-40	7283-5622-40	7283-6447-40
43	A	Black 34x1.5, 6x2.8, 3x6.3	---	7282-4190-30	---	7283-4190-30
43	B	Light Grey 34x1.5, 6x2.8, 3x6.3	---	7282-4192-40	---	7283-4192-40







### Applicable Terminal Removal Tool/Dimensions

Refer to Page 52-53 for YESC KAIZEN Connector Terminal Removal Tool.  
 Order Number: 49YA000263 (for 0.64 terminal), X39899-J374 (for 1.5 and 2.8 terminal), and  
 G0406 (PA Type) (for 6.3 terminal).

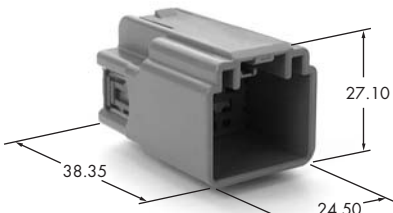
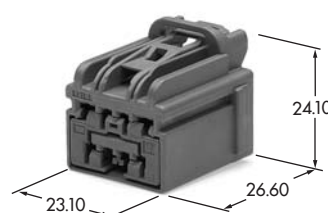
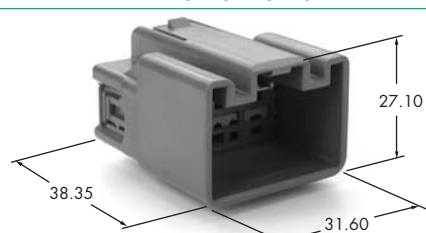

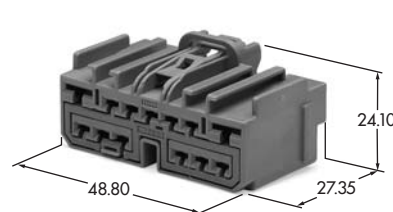
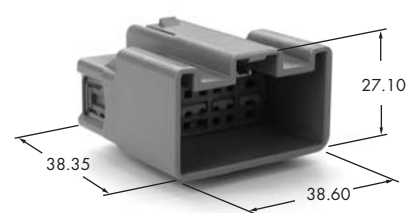
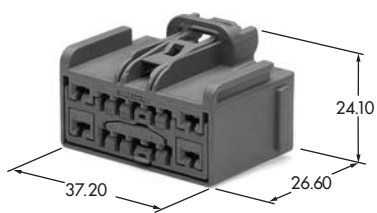
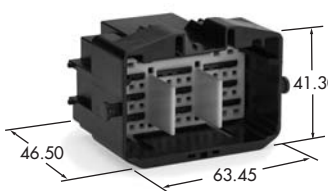
Housing Material: PBT+GF

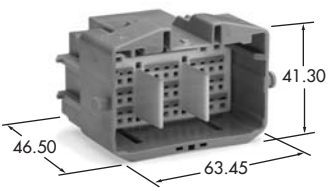
UNIT: mm

Poles	Male Housing	Female Housing
8	 <p>7282-6448-40</p>	 <p>7283-6448-40</p>
10	 <p>7282-6459-40</p>	 <p>7283-6459-40</p>
13	 <p>7282-6569-40</p>	 <p>7283-6569-40</p>
14	 <p>7282-6447-40</p>	 <p>7283-6447-40</p>
43	 <p>7282-4190-30</p>	 <p>7283-4190-30</p>
43	 <p>7282-4192-40</p>	 <p>7283-4192-40</p>

# General: Yazaki Part Numbering Methodology

## Production:

No suffix indicates: Natural Color for plastics, and black for rubbers. Terminals which do not have a suffix may or may not have Sn plating



Miscellaneous Component\* = Cable Seal, Clip, Wire Shield, TPA, CPA, etc.

Yazaki confidential



YPES-15-298

Handling Manual  
For  
YESC  
1.5 System Sealed

<Note> This document is subject to revision  
without notification.

YAZAKI PARTS CO., LTD  
YAZAKI CORPORATION  
August. 03. 2001

# Table of Contents

- 1. Description of Parts Features and Functions . . . . . P. 3
  - 1-1. Male Terminal Features and Functions . . . . . P. 3
  - 1-2. Female Terminal Features and Functions . . . . . P. 4
  - 1-3. Male Housing Features and Functions . . . . . P. 5
  - 1-4. Female Housing Features and Functions . . . . . P. 6
  
- 2. Parts Storage, Transportation and Handling Precautions . . . . . P. 7
  - 2-1. Terminals . . . . . P. 7
    - 1) Transportation . . . . . P. 7
    - 2) Storage . . . . . P. 8
  - 2-2. Housings etc. . . . . P. 8
  
- 3. Terminal Crimping Specifications . . . . . P. 9
  - 3-1. Crimping Standards . . . . . P. 9
  - 3-2. Crimping Process Check Points and Judgement Criteria . . . . . P. 9
  - 3-3. Measurement Points of Specified Crimp Dimensions . . . . . P. 13
  - 3-4. Method for Measurement of Crimp Height and Crimp Width . . . . . P. 13
  - 3-5. Measurement Equipment . . . . . P. 14
  
- 4. Handling Recommendation for Terminated Wires . . . . . P. 15
  
- 5. Terminal and Front Holder Setting Instructions and Precautions . . . . P. 16
  - 5-1. Male/Female Terminal Installation to Housing . . . . . P. 16
  - 5-2. Male Front Holder Setting on Male Housing . . . . . P. 17
    - 1) Male Front Holder Function . . . . . P. 18
  - 5-3. Female Front Holder Setting on Female Housing . . . . . P. 19
    - 1) Female Front Holder Function . . . . . P. 20
  
- 6. Terminal and Front Holder Removal Instructions and Precautions . . . . P. 21
  - 6-1. Disengagement of Front Holder from Full-Lock Position, Male . . . . P. 21
  - 6-2. Disengagement of Front Holder from Full-Lock Position, Female . . . . P. 22
  - 6-3. Terminal Removal . . . . . P. 23
  - 6-4. Male Front Holder Removal & Insertion Tool Shape . . . . . P. 26
  - 6-5. Terminal Removal Tool Shape . . . . . P. 26
  
- 7. Dummy Plug Setting and Removal Instructions and Precautions . . . . . P. 27
  - 7-1. Dummy Plug Setting . . . . . P. 27
  - 7-2. Dummy Plug Removal . . . . . P. 27

- 8. Connector Position Assurance (CPA) Function . . . . . P. 28
  - 8-1. How to Lock the CPA . . . . . P. 28
  - 8-2. How to Unlock the CPA . . . . . P. 29
  
- 9. Precautions During Wire Harness Assembly . . . . . P. 30
  - 9-1. Wire Harness Assembly . . . . . P. 30
  - 9-2. Taping . . . . . P. 30
  - 9-3. Inspection . . . . . P. 31
  
- 10. Notice for Packing of Wire Harness . . . . . P. 32
  
- 11. Precautions During Wire Harness Installation into the Vehicle . . . P. 34
  - 11-1. Connector Mating . . . . . P. 34
  - 11-2. Connector Servicing . . . . . P. 35
  
- © Connector Configurations and Figures of Part Numbers . . ATTACHED P. 1 ~ 11

1. Description of Parts Features and Functions

1-1. Male Terminal Features and Functions

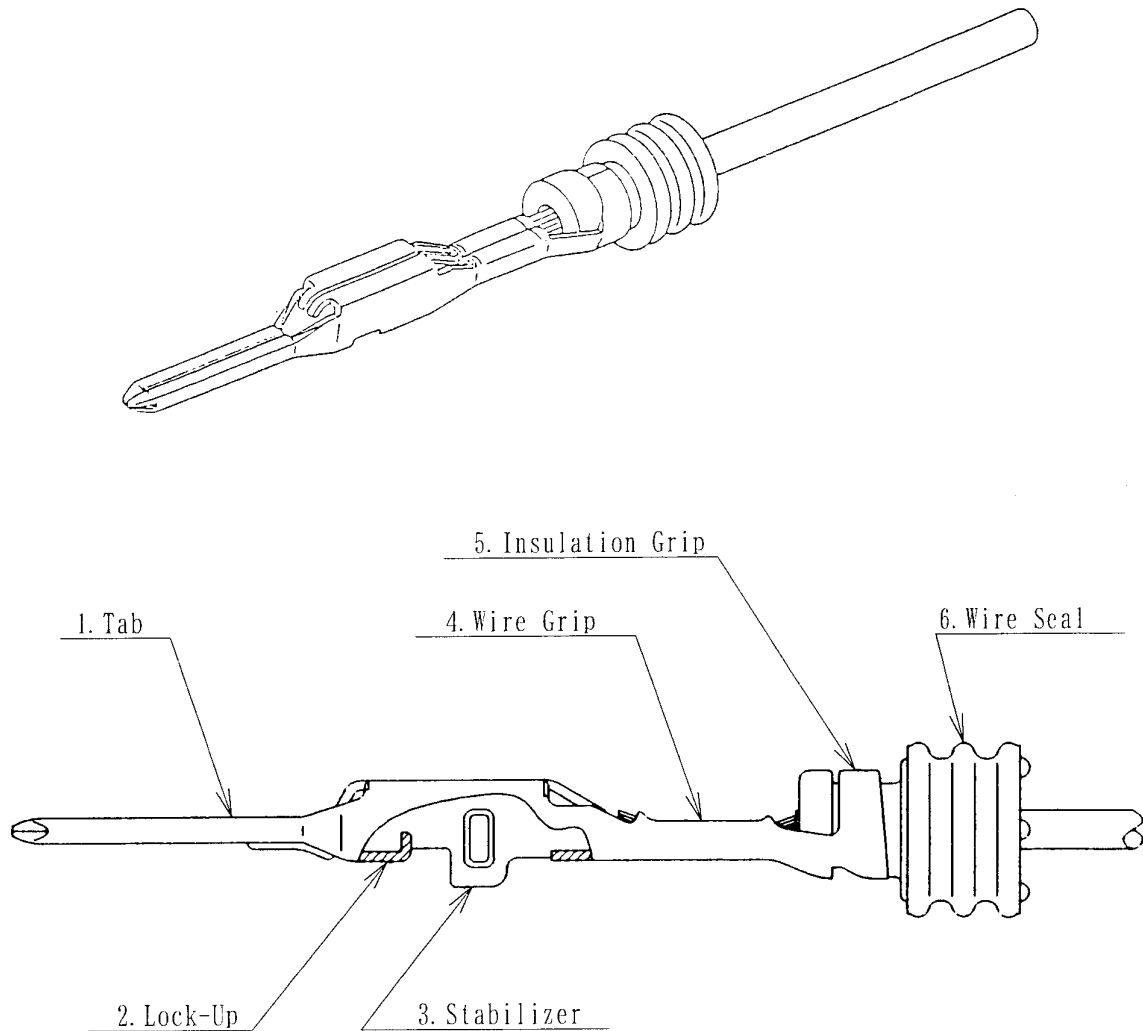

No.	Feature Name	F u n c t i o n
1	Tab	Contact with Female Terminal
2	Lock-Up	Provide Surface for Lock-up With Terminal Cavity Lock-arm
3	Stabilizer	Prevent Terminal reverted Insertion
4	Wire Grip	Conductor Crimping
5	Insulation Grip	Insulation Crimping
6	Wire Seal	Seal between Wire and Housing

1-2. Female Terminal Features and Functions

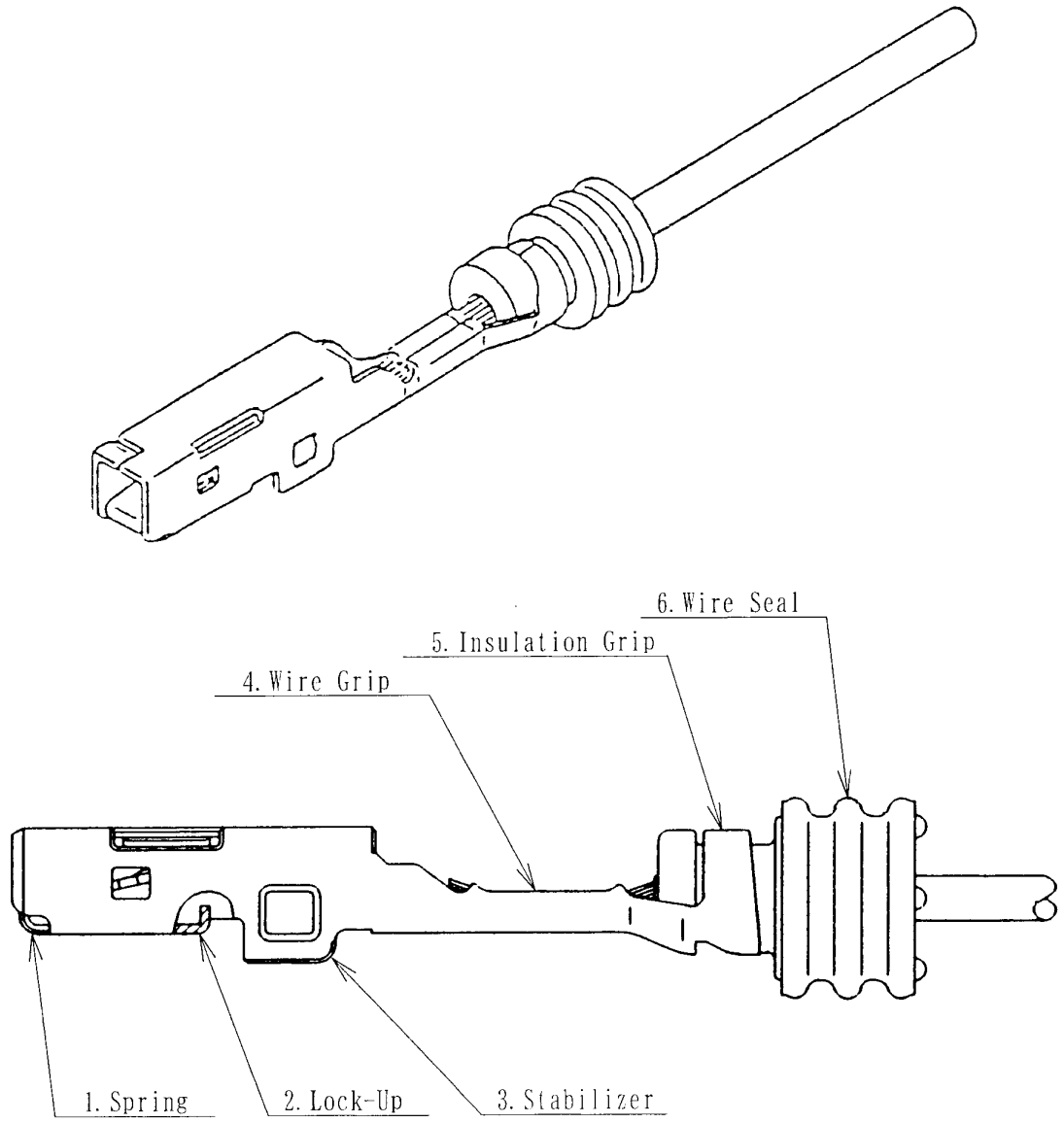

No.	Feature Name	F u n c t i o n
1	Spring	Contact with Male Terminal
2	Lock-Up	Provide Surface for Lock-up With Terminal Cavity Lock-arm
3	Stabilizer	Prevent Terminal reverted Insertion
4	Wire Grip	Conductor Crimping
5	Insulation Grip	Insulation Crimping
6	Wire Seal	Seal between Wire and Housing

1-3. Male Housing Features and Functions

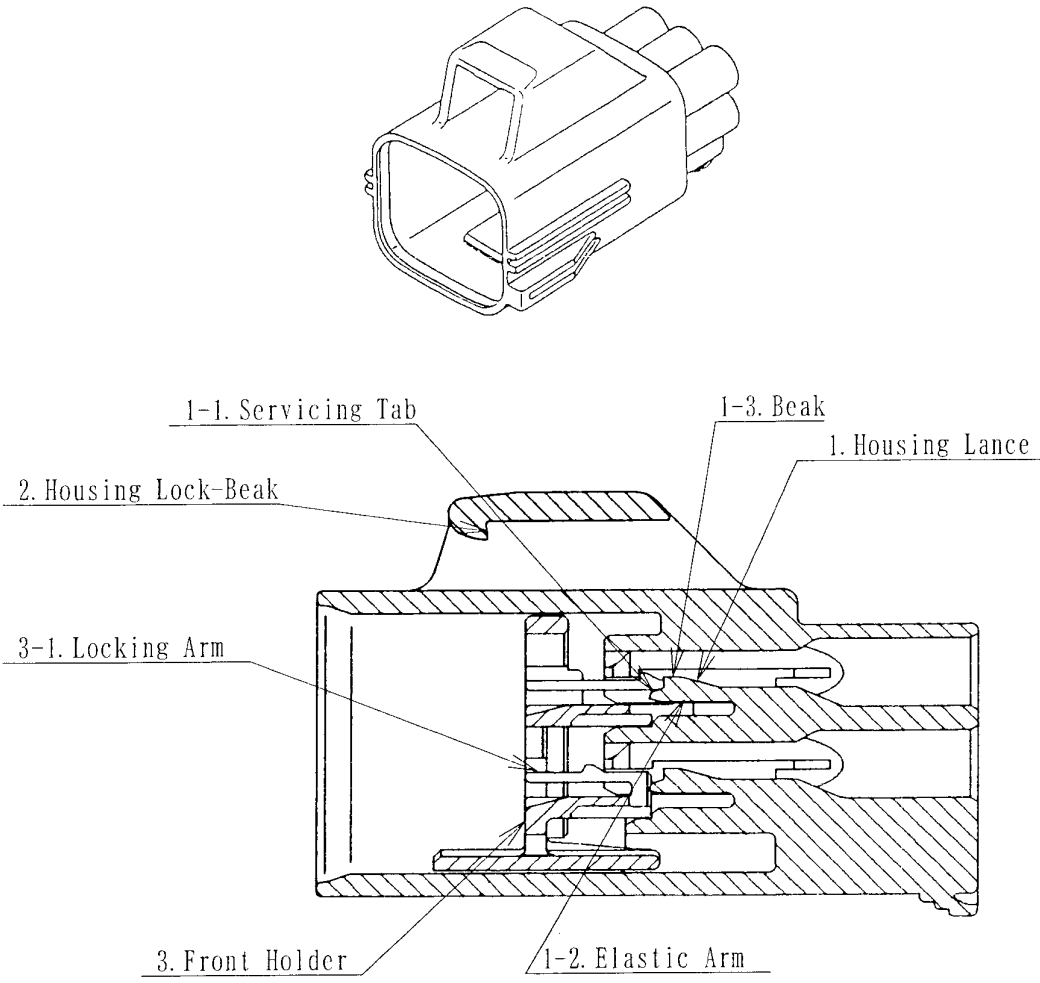

NO.	Feature Name		Function
1	Housing Lance		Snap-fit Feature for Male Terminal
	1-1	Servicing Tab	Release of Housing Lance
	1-2	Elastic Arm	Allow Movement of Beak
	1-3	Beak	Lock/Retention of Male Terminal
2	Housing Lock-Beak		Lock/Retention of Female Housing
3	Front Holder		Terminal Position Assurance
	3-1	Locking Arm	Setting and Releasing of Front Holder



1-4. Female Housing Features and Functions

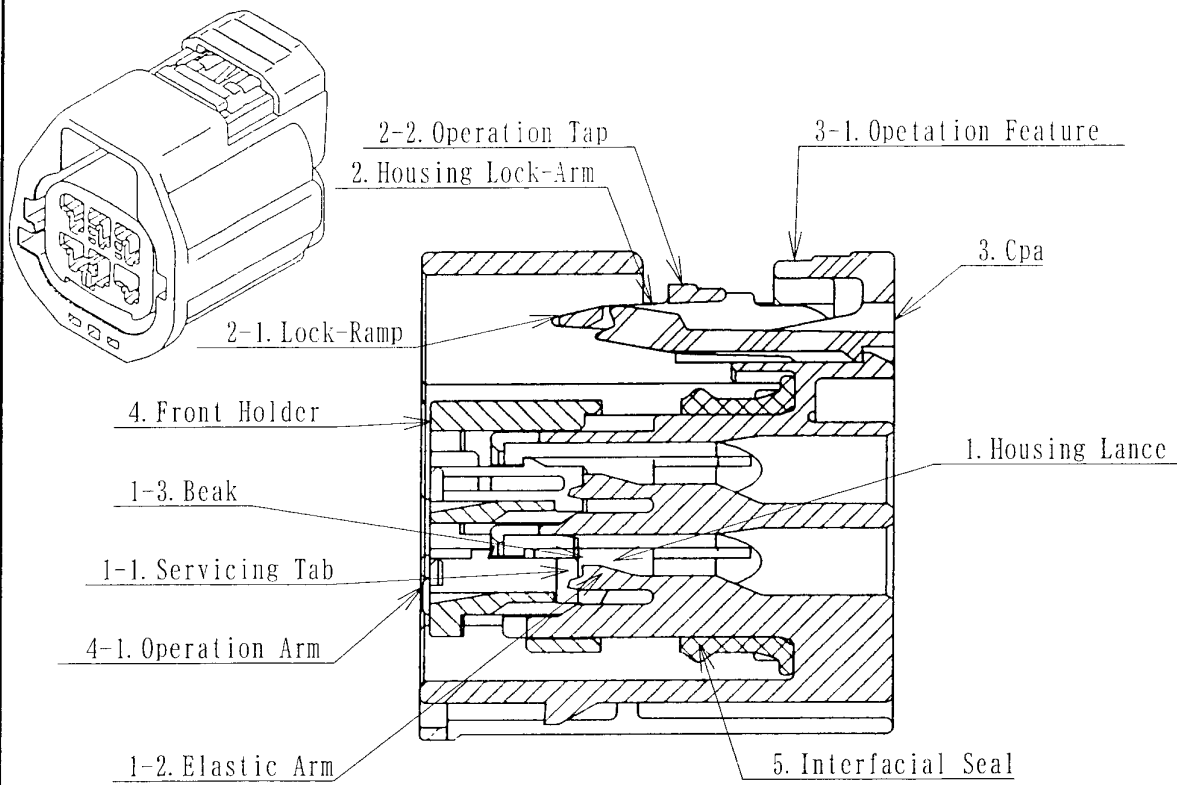

NO.	Feature Name		F u n c t i o n
1	Housing Lance		Snap-fit Feature for Female Terminal
	1-1	Servicing Tab	Release of Housing Lance
	1-2	Elastic Arm	Allow Movement of Beak
	1-3	Beak	Locking/Retention of Female Terminal
2	Housing Lock-Arm		Lock with Male Housing
	2-1	Lock-Ramp	Lock/Retention of Male Housing
	2-2	Operation Tap	Release of Housing Lock for Service
3	Cpa (Connector Position Assurance)		Housing Full-Male Detection
	3-1	Operation Feature	Operation of Cpa
4	Front Holder		Terminal Position Assurance
	4-1	Operation Arm	Setting and Releasing of Front Holder
5	Interfacial Seal		Sealing Between Mated Housings

## 2. Parts Storage, Transportation and Handling Precautions

The parts must be free of deformation, damage, etc. during storage and transportation.

### 2-1. Terminals

- Partial terminal reels should have the carrier strip secured to prevent reel unwinding of terminal entanglement. Recommended method is shown below.
- Recommended storage and transportation of terminal reels is shown below.

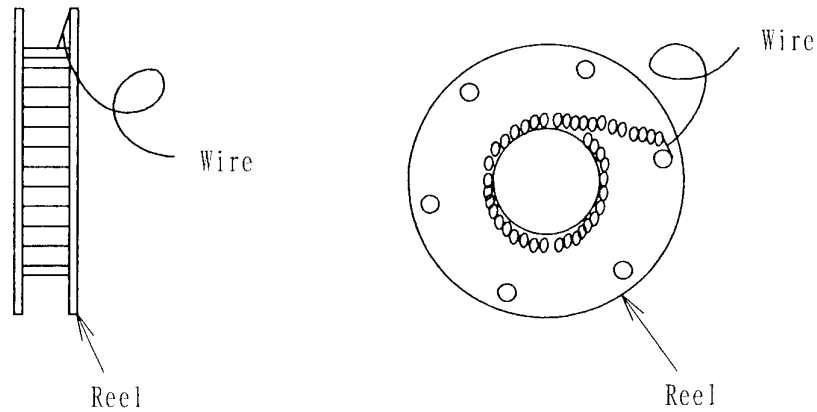

### 1) Transportation

- Reels should be packed (protected) to avoid any harsh impacts during transportation.
- Care should be taken to avoid any harsh impacts by dropping from high position.
- When carrying reels out of a box, take extra care not to break the reels because it is made of paper.

Recommended Method

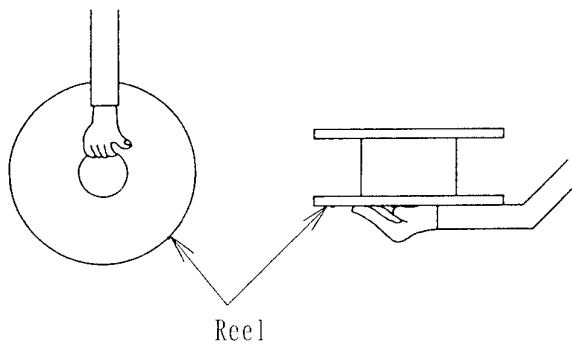

Poor Practice

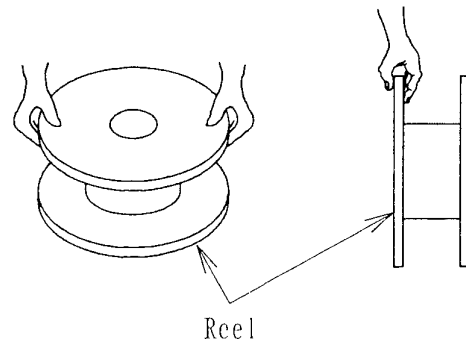

2) Storage

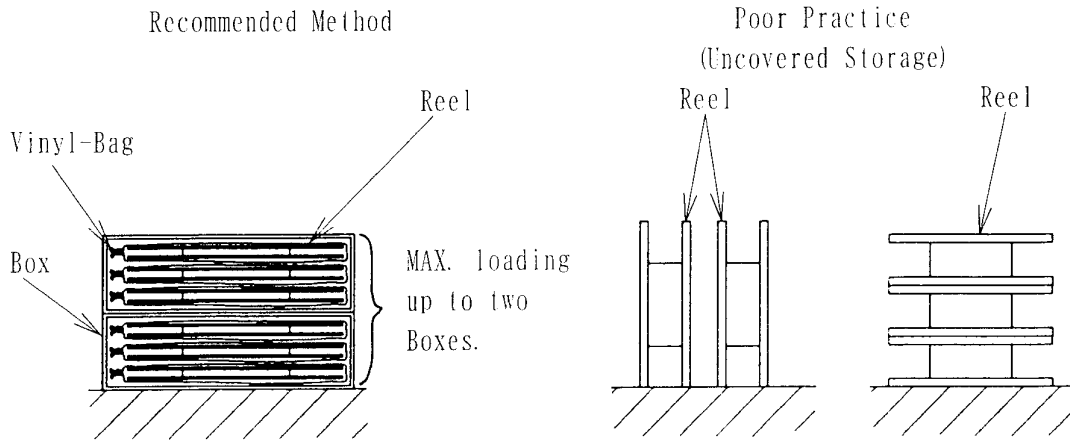

2-2. Housings etc.

- Parts should be stored in the box or plastic bag in which they were shipped.
- Parts should be stored indoors, away from direct sunlight.
- Parts should be stored in an area void of excess humidity.
- Parts must not be stored in an uncovered or unprotected condition.  
(i. e., parts should be protected from water, oil, dust, etc.)
- Care should be taken to avoid any harsh impacts on the part containers during transportation.
- Care should be taken to avoid any harsh impacts by dropping from high position.

### 3. Terminal Crimping Specifications

#### 3-1. Crimping Standards

Contact our sales department for the official crimping standard.



<NOTE> · Pay attention to crimp within the limit on the crimping standard. If it is out of the standard, because retention force of the crimping area and electrical resistance are not satisfied, the function of the part may be affected.

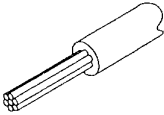
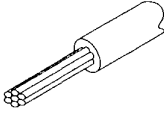
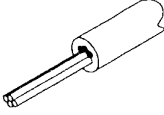
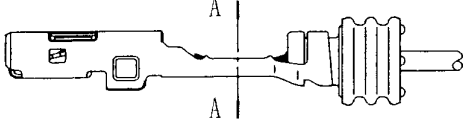
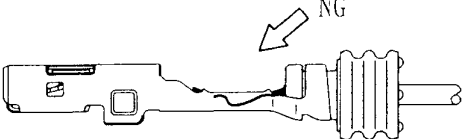
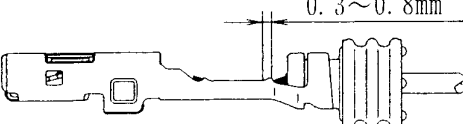
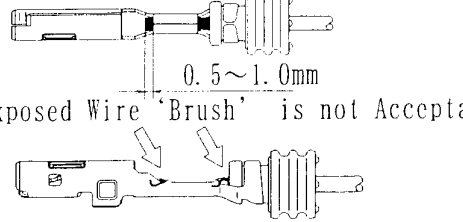

· The above is limited to the case when Yazaki's crimping tool is used.

#### 3-2. Crimping Process Check Points and Judgement Criteria

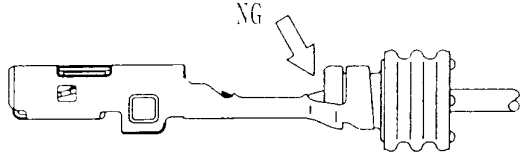
During the crimping process care must be taken to assure the following items are correct.

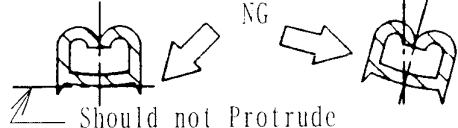
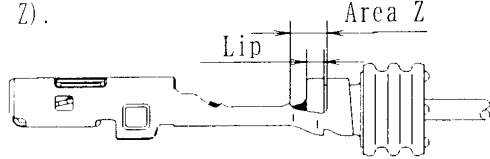
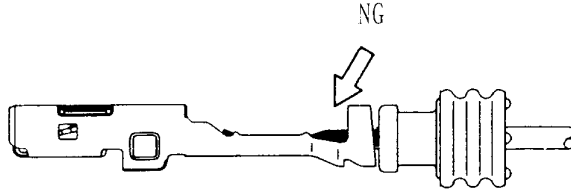
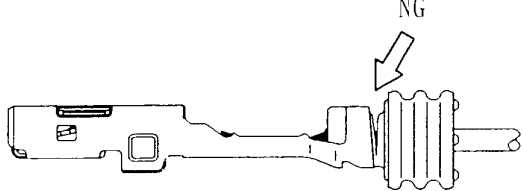
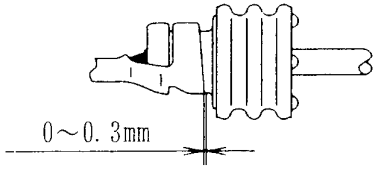
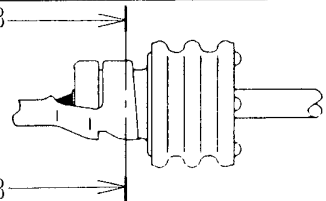
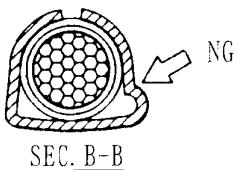
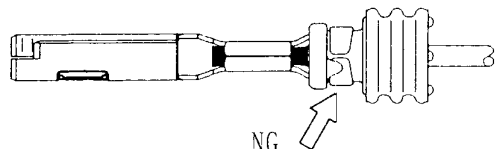
ITEM	CHECK POINT	JUDGEMENTS		
Insul. Stripping	<ul style="list-style-type: none"> <li>• Conductor Diagonal Cutting</li> <li>• Conductor Cut</li> <li>• Any Flaw on Conductors</li> <li>• Insuation Diagonal Cut</li> <li>• Any Damage on Insulation</li> </ul>	 <p>Normal</p>	 <p>Conductor Diagonal Cut</p>	 <p>Conductor Cut</p>
Crimping of Conductor Grip Male/Female	Normal Crimping Condition			
	Any Conductor Flaw			
	Bell-Mouth			
	Top Length of Conductor			

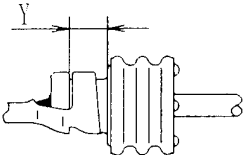
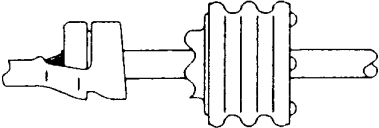
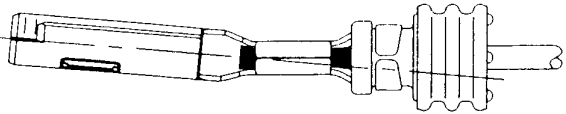
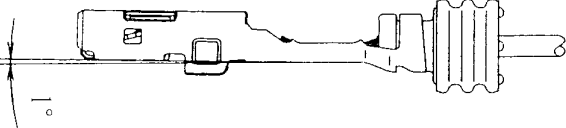
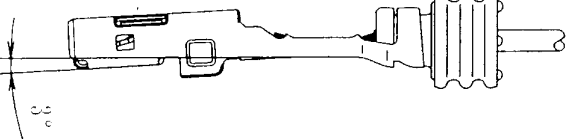
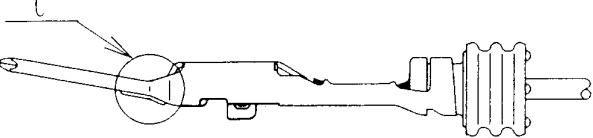
ITEM	CHECK POINT	JUDGEMENTS
Crimping of Conductor Grip Male/Female	Insulation Crimped by Conductor Grip	
	Burr and/or Twist	<p>Normal</p>   <p>Should not Protrude Past this Line.</p>
Crimping of Insulation Grip Male/Female	Normal Crimping Condition	<p>The end of insulation and wire seal must be seen between wire grip and insulation grip (Area Z).</p> 
	Wire Seal Falls short of Insulation Grip	
	Any flaw regarding Wire seal	
	Cut off Length	<p>Cut-off length no damage to wire seal</p> 
	No Crease of Grip	 
	Sliced Wire Seal Insulation Crimp Cuts Into Wire Seal When Crimped	

ITEM	CHECK POINT	JUDGEMENTS
Crimping of Insulation Grip Male/Female	Wire Seal Position	The insulation grip must fall between sealing rib and attachment lip (Area Y). 
	Wire Seal Scratch or Cut	Scratch or cut on wire seal is not acceptable. 
Crimp Discrepancy Deformed by Crimping Male/Female	Twist	Twisted terminals should be rejected during visual checking. 
	Bent up	The degree of bending must be 1° or less. 
	Bent Down	The degree of bending must be 3° or less. 
	Tab Deformation Male Only	Deformation at point C is not acceptable. 
	Crimp Discrepancy	

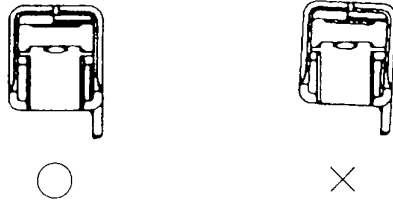
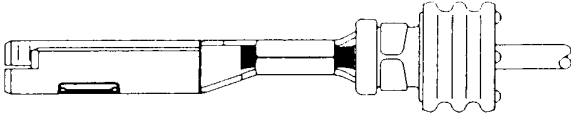
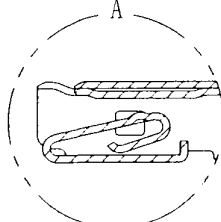
ITEM	CHECK POINT	JUDGEMENTS
Deformed by Crimping Male/Female	Box Misalignment Female Only	
	Defect of Terminal Feeding	
Terminal Deformation Female Only	Terminal Deformation at A	Terminal deformation at A is not acceptable.  

3-3. Measurement Points of Specified Crimp Dimensions

The optimum crimp dimensions should be as close to nominal as possible.

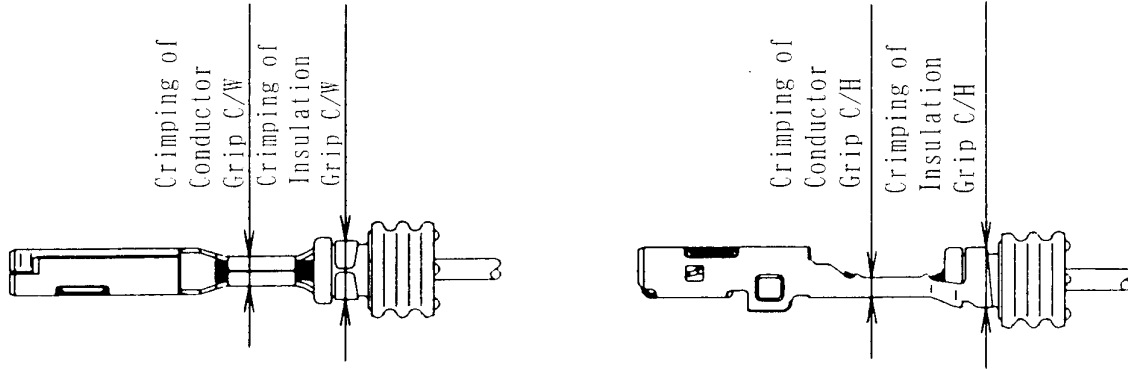

C/H should not be measured at this point

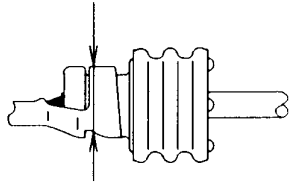

3-4. Method for Measurement of Crimp Height and Crimp Width

Conductor crimp : C/H and C/W should be measured at the center of the crimp using a micrometer.

Crimp Height

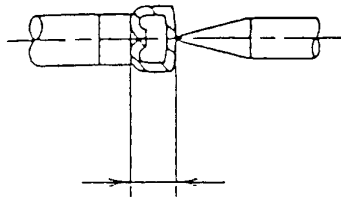

Crimp Width

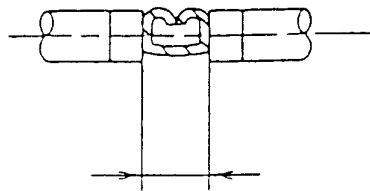

Insulation crimp : C/H and C/W should be measured at the center of the crimp using a micrometer.

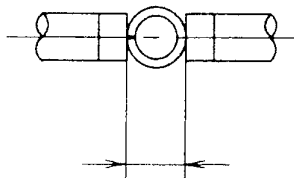

C/H

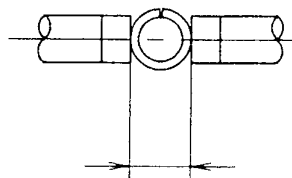

C/W



3-5. Measurement Equipment

The micrometer used for measurement should be similar to the device shown below. In order to obtain the most accurate measurement possible, it is recommended that the micrometer is mounted on a stand during use.

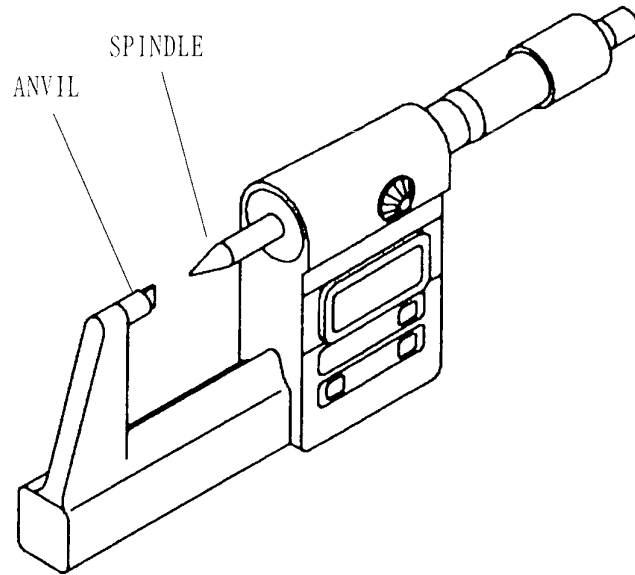

ANVIL

SPINDLE A

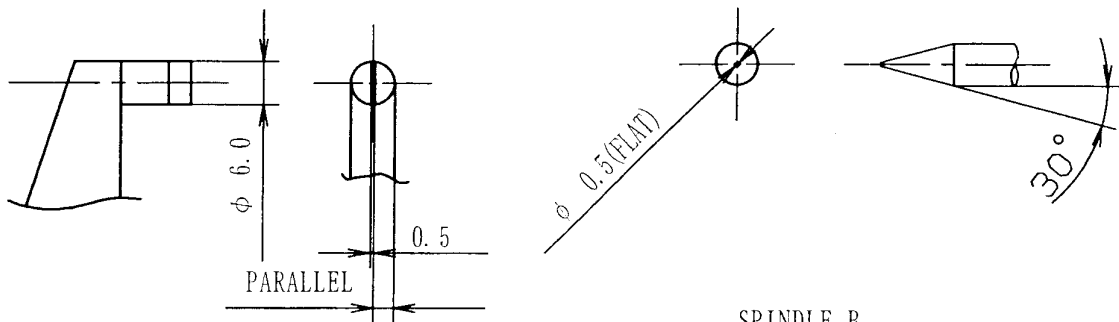

SPINDLE B

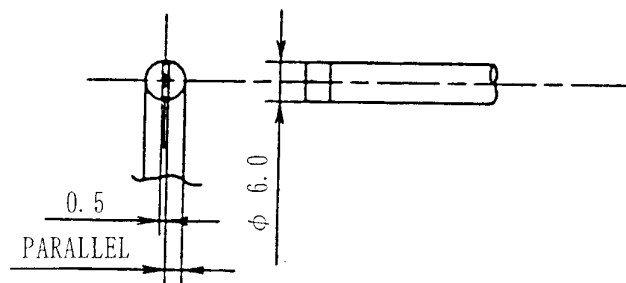

Use spindle A for the C/H measurement of conductor crimp.

Use spindle B for the C/W measurement of conductor crimp and for C/H and C/W measurement of Insulation crimp.

4. Handling Recommendation for Terminated Wires

Following care must be taken when handling terminated wires so as not to deform (i. e. :bending, deformation) during transportation.

- Terminated wires should be prepared only for subsequent usage rather than for stock/storage because terminated wires before installation into housings are easily broken.
- The number of terminals crimped per wire bundle should range from 50-100 pieces. Bundles should be bound with elastic bands to prevent separation. (If bundled wires are more than 100 pieces, wires may be entangled each other or wiring becomes difficult because of self-weight of the wires. See below.)
- Terminated leads should be covered with protective cover after rapped with vinyl bags to protect the crimped terminals. This bag should not be removed or opened until the leads is included in the harness assembly operation. See below.
- Terminated wires should be transported by using a wire hanging stand or a covered carton/container. Do not pile up the terminated wires. (Pay attention to use the best method for the wires and terminals not to damage then.)
- If the terminated wires must be transported to another facility for assembly, leads should be carefully placed in a covered carton/container. The container should be handled with care in order to avoid damage to crimped terminals.
- During shipping, damage may occur to the wire seal. Assembly workers should check the wire seal for nicks or cuts before usage.

Example for Handling of Terminated Leads

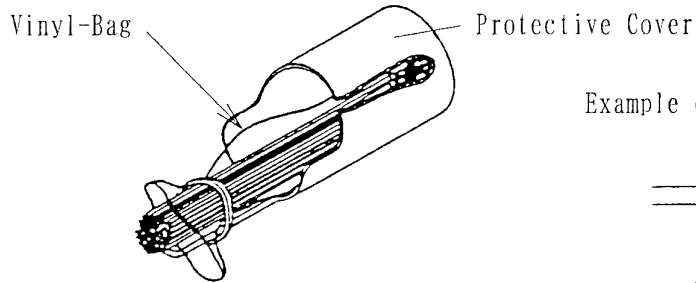

Example of Wire Hanging

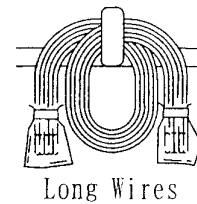
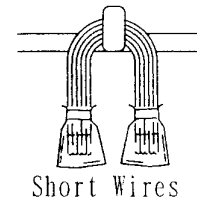
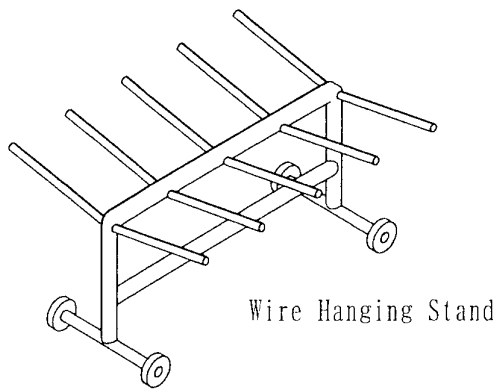

5. Terminal and Front Holder Setting Instructions and Precautions

5-1. Male/Female Terminal Installation to Housing

- After assuring the orientation of the male/female terminals is correct, push the terminal into the appropriate cavity of the male/female housing.  
(The front holder must be in the pre-set position for terminal insertion to occur.)
- Insert the terminal until an audible 'click' sound is heard.
- After inserting the terminal, pull the wire lightly to confirm whether the terminal is surely locked.
- Confirm the rear end of wire seal crimped with terminal is inside the terminal entrance of the housing.

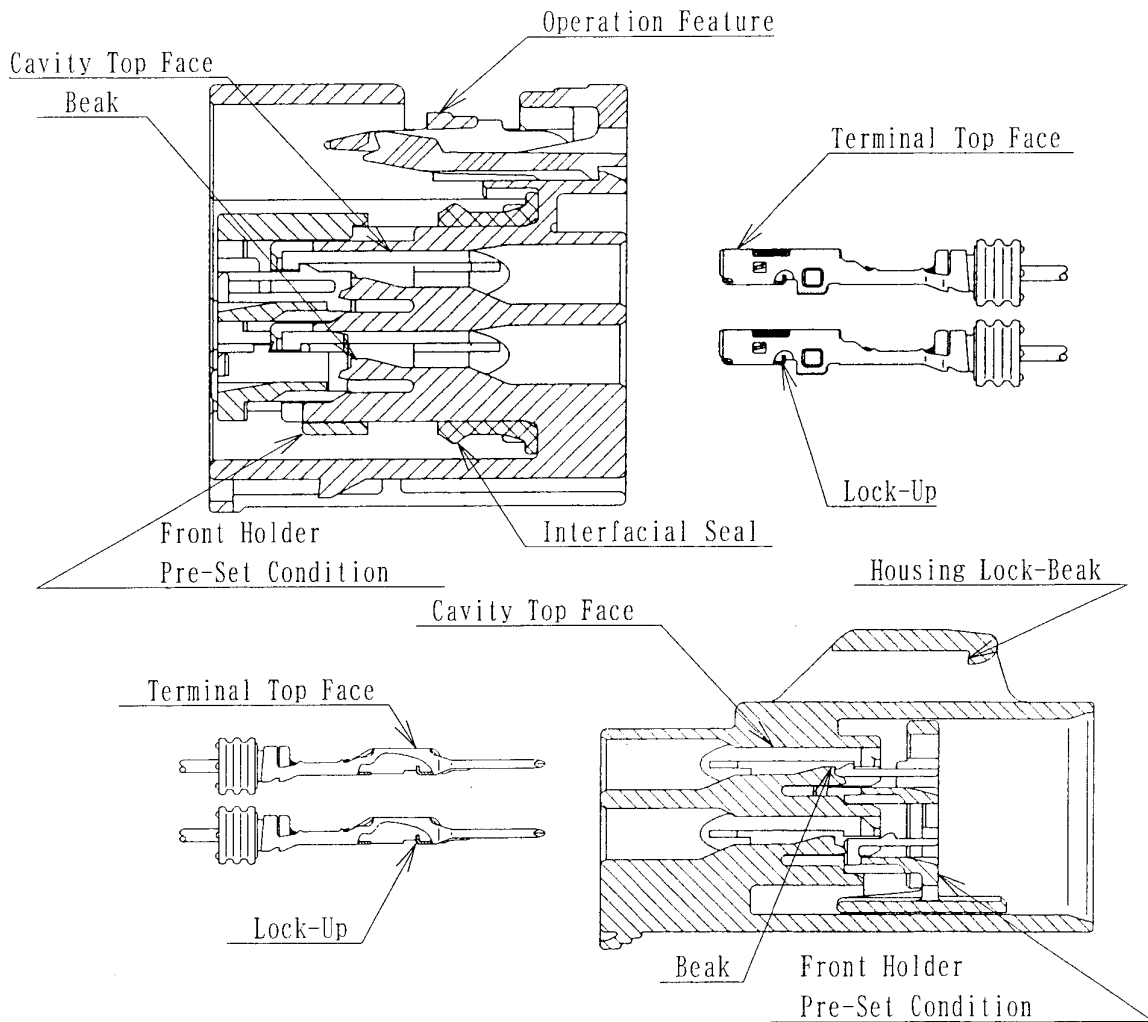

<NOTE> If the front holder is not in the pre-set position, the front holder must first be moved to the pre-set position before terminal insertion.

### 5-2. Male Front Holder Setting on Male Housing

When moving the front holder from the pre-set position to full-lock position, push at area A with the special tool.

- When pushing area A, pay attention not to harm the sealing surface of the housing or the male tab with the tool.
- If it is damaged; replace it with a new one.
- If the front holder is not pushed in to the full-lock position smoothly, the terminal may not have been inserted correctly. (refer to 5-2.1) Do not push in by force.

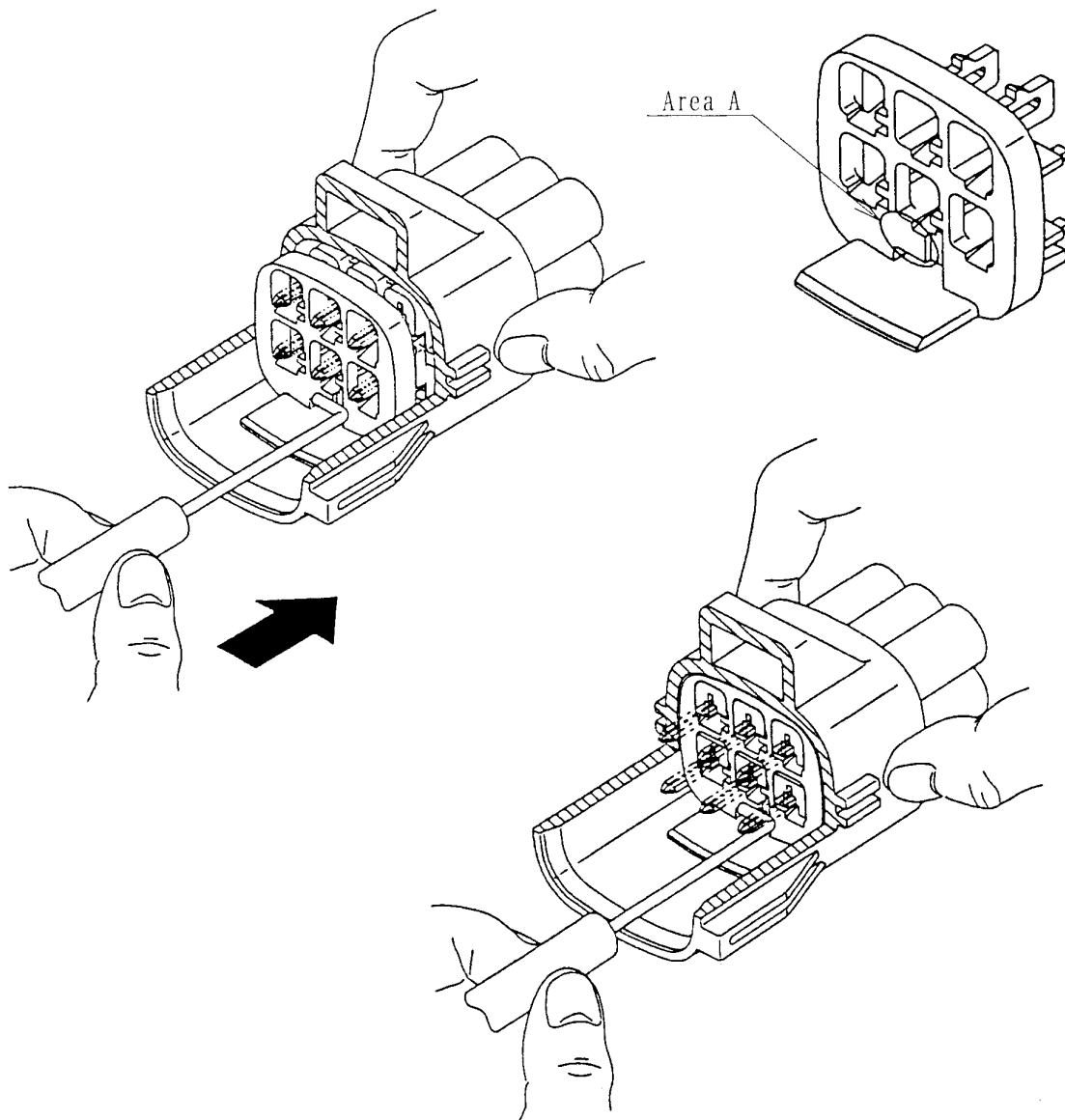

1) Male Front Holder Function

- Engagement of the front holder to the full-installed position cannot be completed if one of the following conditions exist :
  - \* Male terminal(s) is not fully inserted into the cavity.
  - \* Male terminal(s) installed in the wrong orientation.
- After condition(s) noted in item two is/are corrected, the holder can be fully installed. Failure to correct these conditions prior to full holder installation could result in damage to either the holder or the housing.
- Confirmation of full holder installation must be taken by checking refer to the page before.  
Care should be taken to avoid the possibility of partial front holder installation.

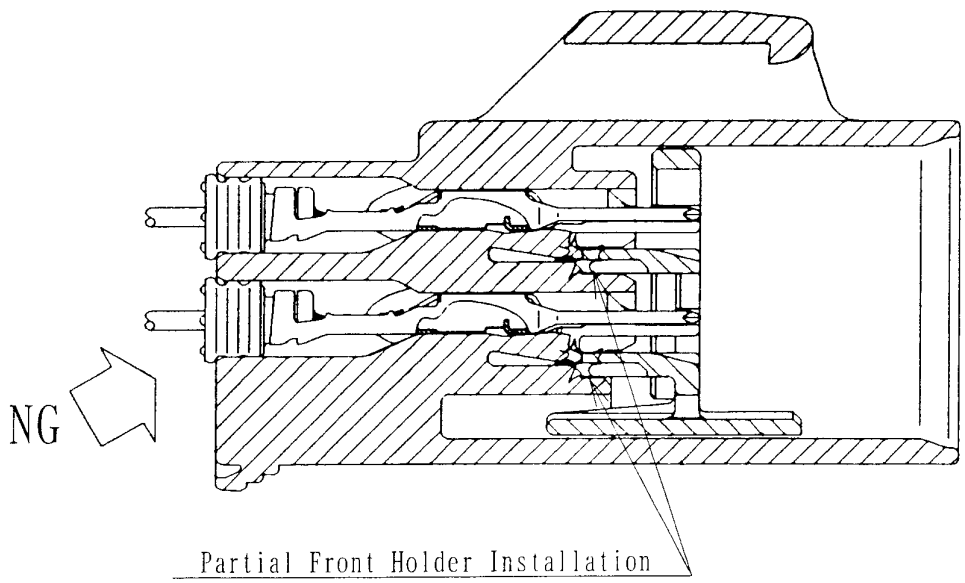

### 5-3. Female Front Holder Setting on Female Housing

The front holder will either be in the pre-set position or full-lock position on the housing. The diagrams below illustrate the appearance of each condition. The spacer can be moved from the pre-set to full-lock position by deflecting the operation arm as shown.

- The operation arm of the holder should be deflected prior to moving the spacer between positions. Failure to deflect the operation arm could result in damage to either the housing or holder feature.
- If the front holder is not pushed in to the full-lock position smoothly, the terminal may not have been inserted correctly. (refer to 5-3.1)) Do not push in by force.

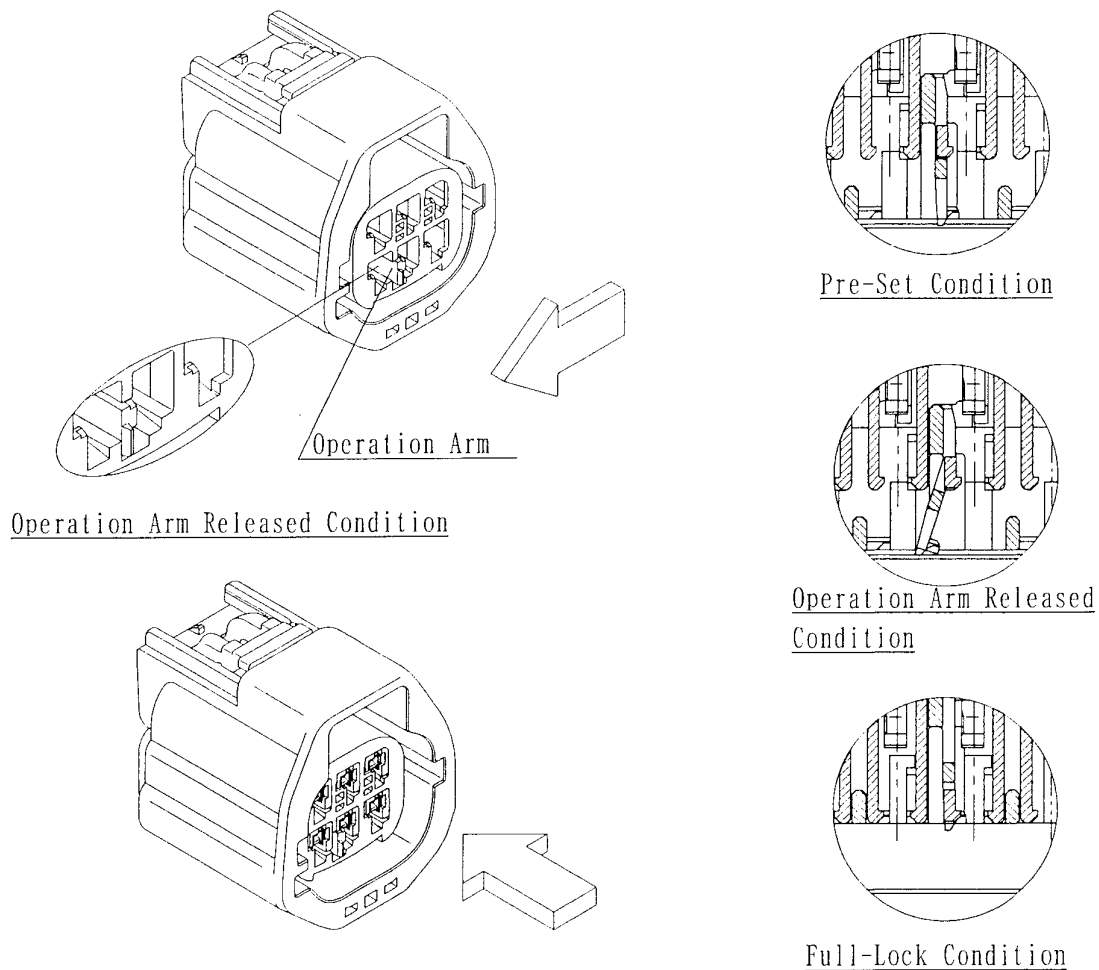

#### <NOTE>

- Must not pull out the front holder more than necessary because it is feared that the primary locking device might be deformed or broken.
- Pay attention not to deform terminal, etc.

#### D) Female Front Holder Function

The front holder must be in the pre-set position prior to the installation of terminals. After installation of all applicable terminals, the front holder must be moved to the full-lock position.

- Engagement of the front holder to the full-installed position cannot be completed if one of the following conditions exist :
  - \* Female terminal(s) is not fully inserted into the cavity.
  - \* Female terminal(s) installed in the wrong orientation.
- After condition(s) noted in item two is/are corrected, the holder can be fully installed. Failure to correct these conditions prior to full holder installation could result in damage to either the holder or the housing.
- Confirmation of full holder installation must be taken by checking refer to the page before.  
Care should be taken to avoid the possibility of partial front holder installation.

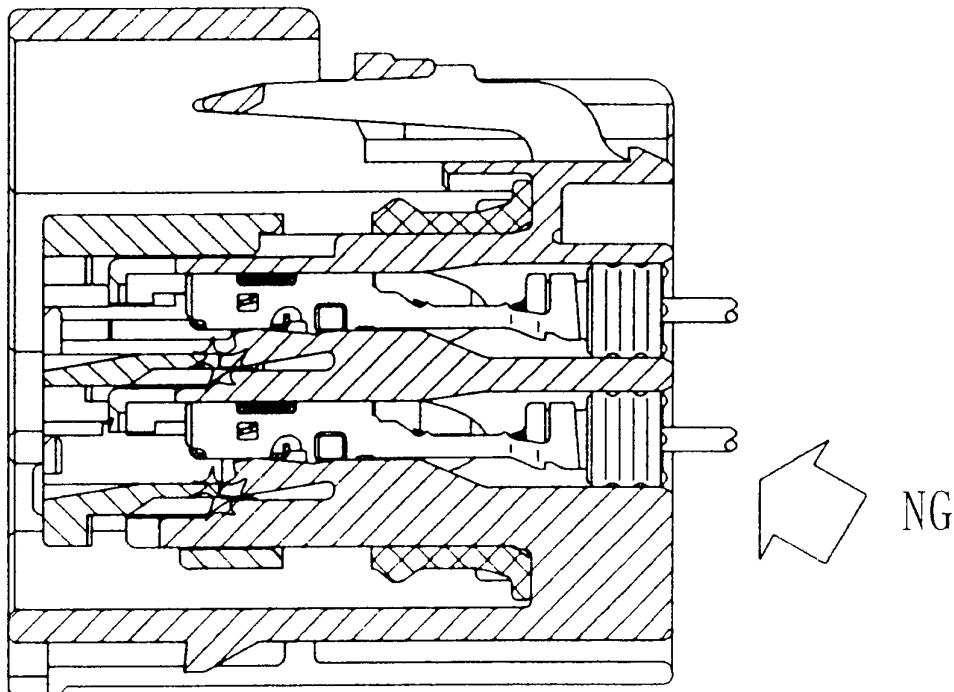

6. Terminal and Front Holder Removal Instructions and Precautions

The following procedures should be used when removing and/or servicing the terminals of this connection system.

6-1. Disengagement of Front Holder from Full-Lock Position. Mail

- As shown below, insert hook tool into slot provided. As slight pull of hook tool in direction of the arrow will release the holder for terminal removal.
- When disengaging the front holder from full-lock position, pay strict attention not to harm the sealing surface or the male tab with special tool.
- If the sealing surface or the male tab is damaged, replace it with a new one.
- Check if the front holder is surely returned to pre-set position.

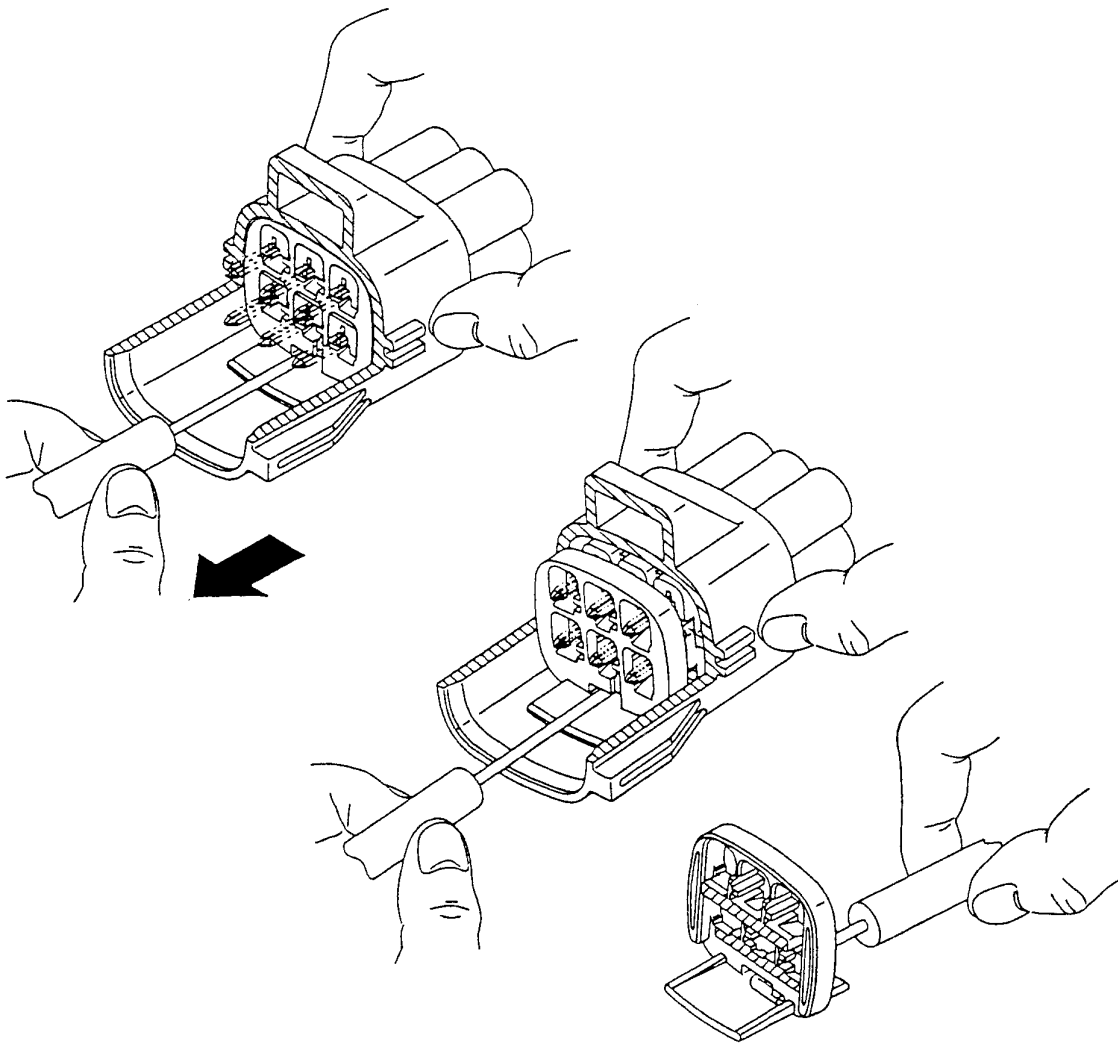



## 6-2. Disengagement of Front Holder from the Full-Lock Position, Female.

- As shown below, move the operation arm of the front holder from right to left to release the secondary lock of the front holder.
- Pull out the front holder to its primary locking position while the operation arm is being deflected.
- Check if the front holder is surely returned to the primary locking position.

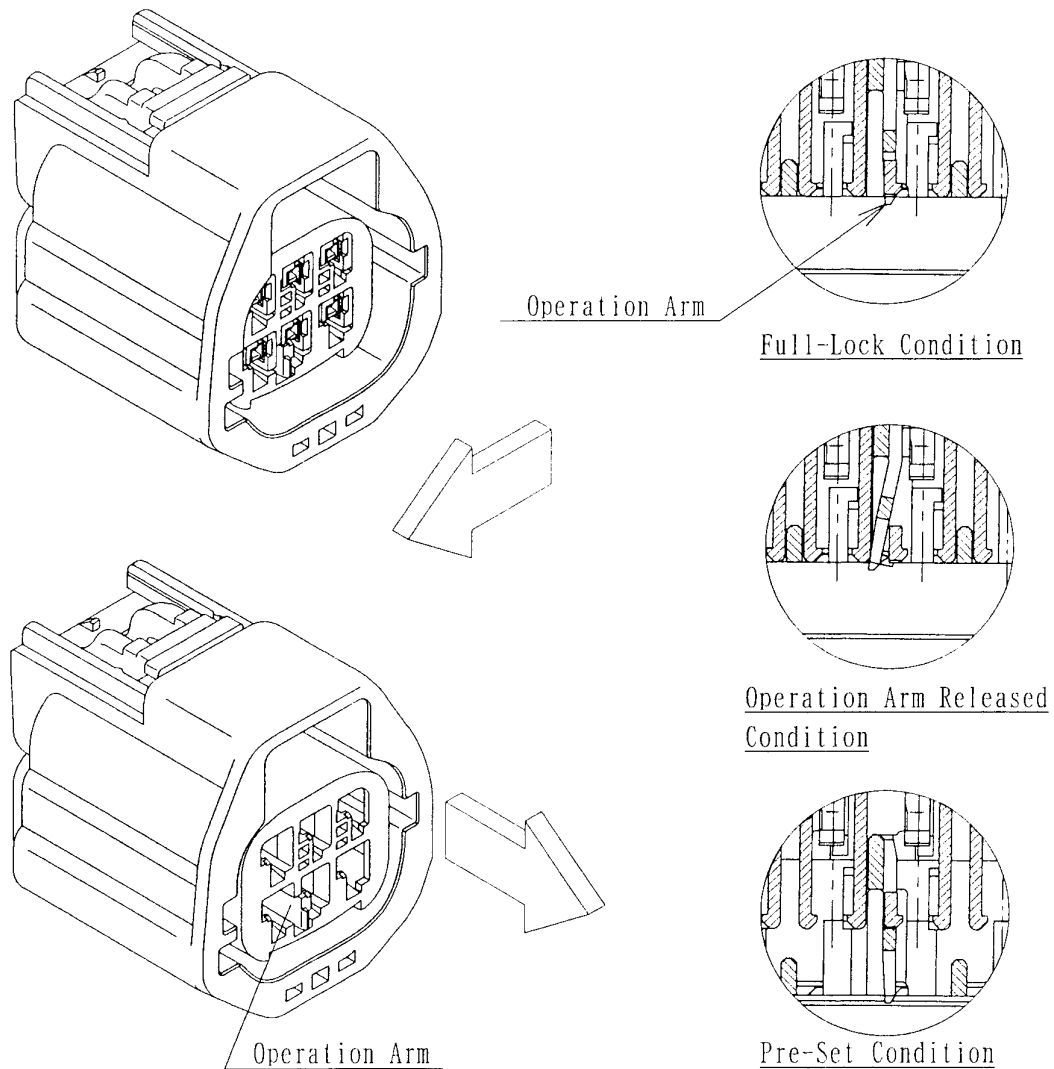

## &lt;NOTE&gt;

- Must not pull out the front holder more than necessary because it is feared that the primary locking device might be deformed or broken.
- When removing terminal with jig, pay attention not to deform terminal, etc.

### 6-3. Terminal Removal

The terminal removal operation should be performed by trained personnel only. Probing of the terminal/cavity by technicians not familiar with the removal process could result in damage to the terminal and/or connector.

- Push the applicable wire lightly to assure the terminal is fully forward in the terminal cavity.
- Insert the removal tool parallel to the cavity into the face of the terminal cavity on the next page. The tip of tool must be positioned between the servicing tab of the flexible arm and the terminal.
- With the flexible arm deflected, pull the wire parallel to the cavity to remove the terminal from the cavity. If the terminal does not disengage easily from the housing, repeat the steps previously outlined.
- If any damage is visible on the terminal and/or housing, the affected component should be replaced; repairs should not be attempted.
- See illustrations on following pages.

• Male Terminal Removal

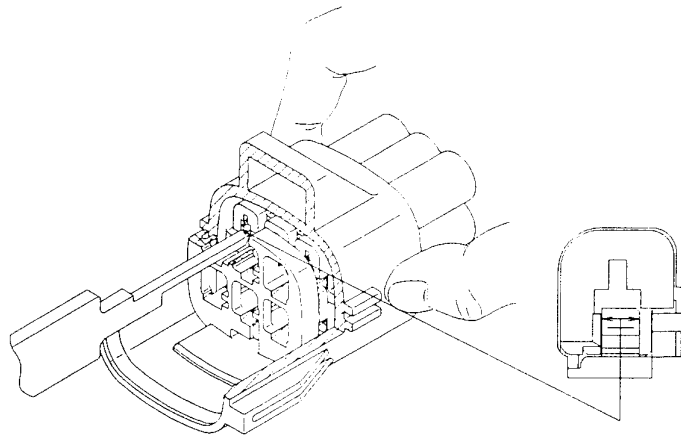

Terminal Tool Guide Surface

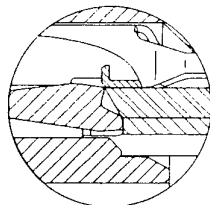
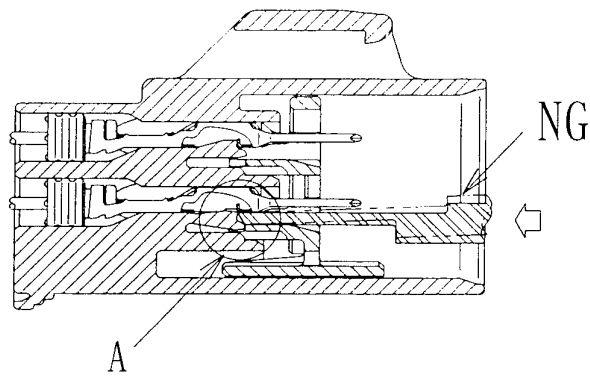

DETAIL A

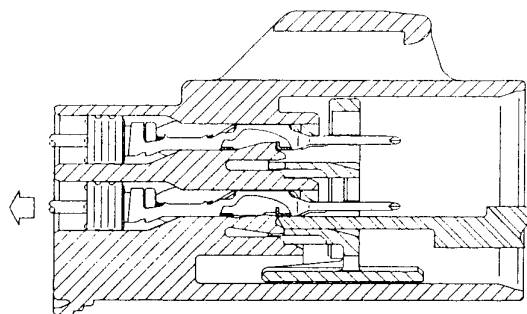

• Female Terminal Removal

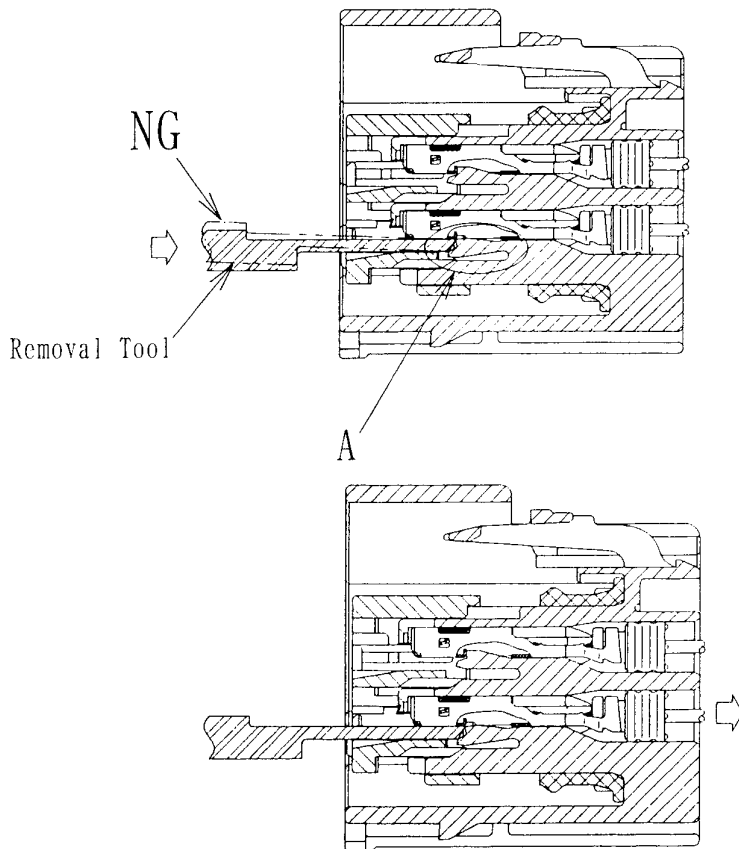
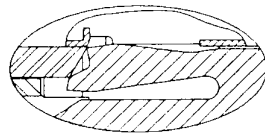
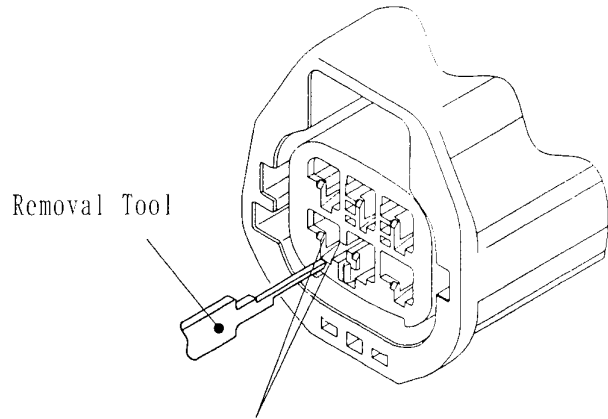

6-4. Male Front Holder Removal & Insertion Tool Shape

The dimensions of the specialized tool recommended for this system are shown below.

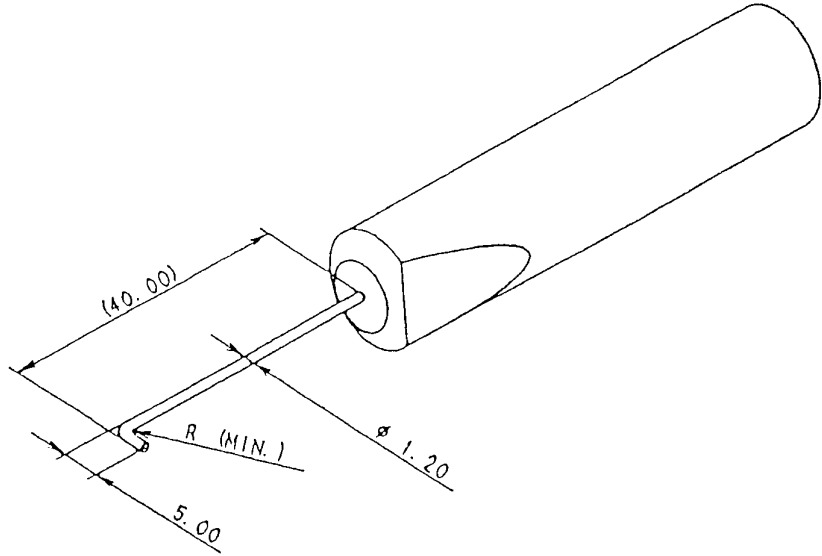

6-5. Terminal Removal Tool Shape

The dimensions of the specialized tool recommended for this system are shown below.

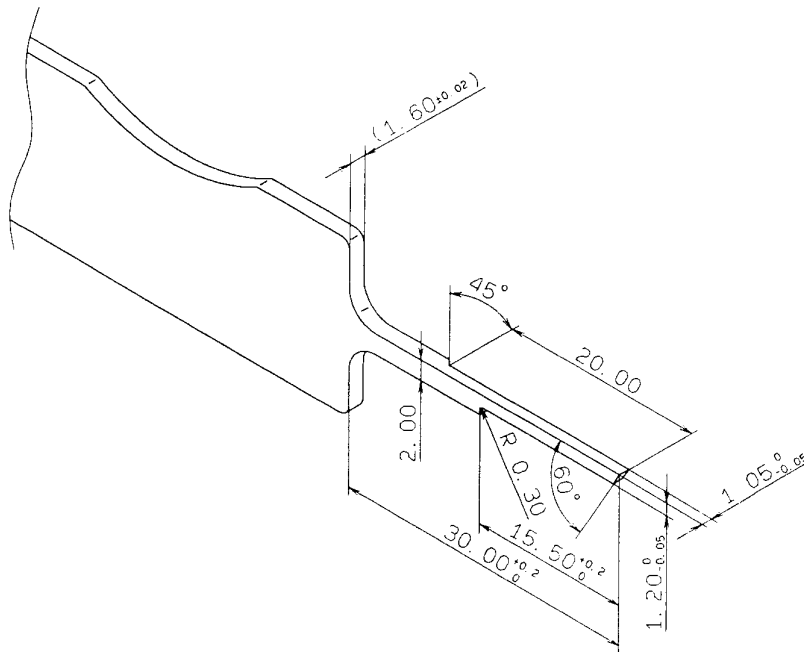

PART NO. : 48ZZ4009

7. Dummy Plug Setting and Removal Instructions and Precautions

7-1. Dummy Plug Setting

The dummy plug is pushed into the open cavity by finger etc.

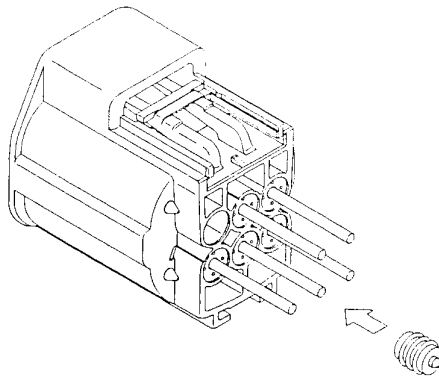

<NOTE> Make sure that the dummy plug has been fully inserted and that the rear side of the seal is not protruding from the cavity.

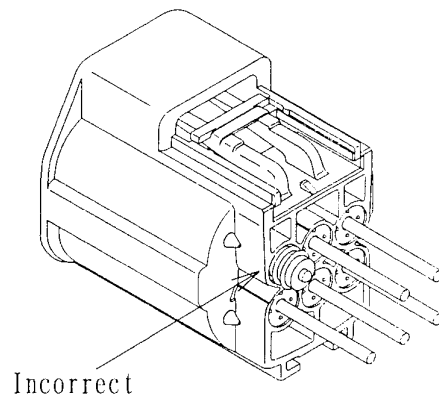
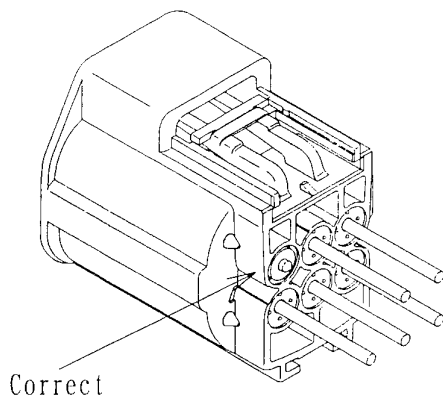

7-2. Dummy Plug Removal

The dummy plug is drawn out from the housing by fingers or pliers etc.

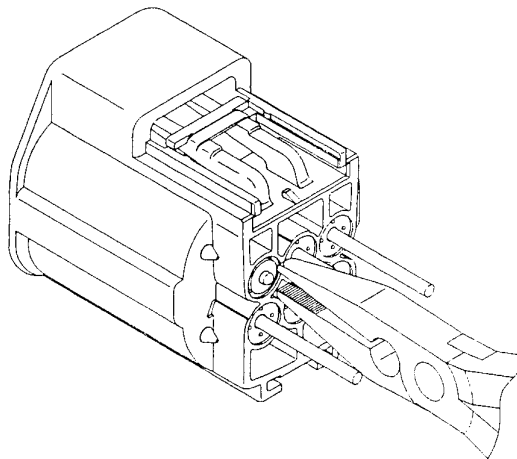

8. Connector Position Assurance (CPA) Function

8-1. How to Lock the CPA

- When the male and female connectors are mated completely, the CPA may be slid into position against the back wall. The back wall is marked by 'A' in the illustration below.

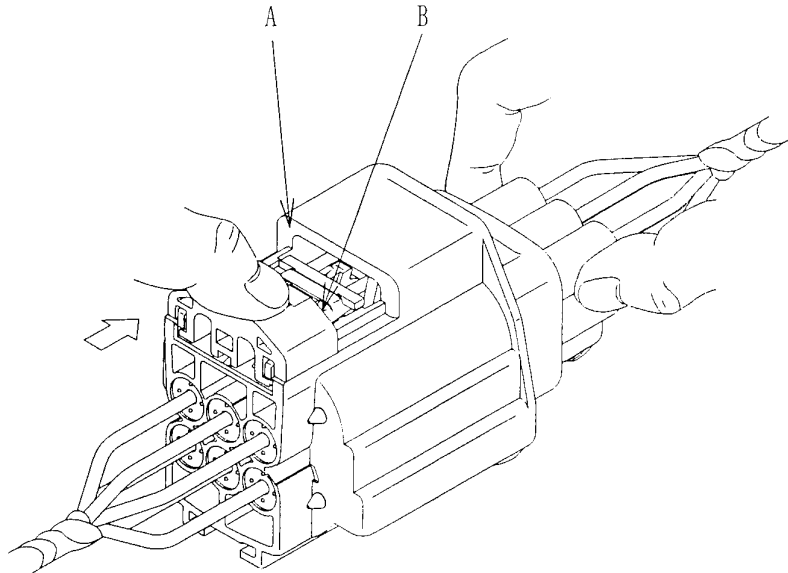

- If the male and female connectors are not fully mated, the CPA, marked by 'B' will not slide to the back connector 'A' (see illustration below). The CPA should never be forced into position, it should slide smoothly and come to rest against the back wall of the connector. If the CPA does not slide smoothly, check and make sure that the connectors are fully mated.

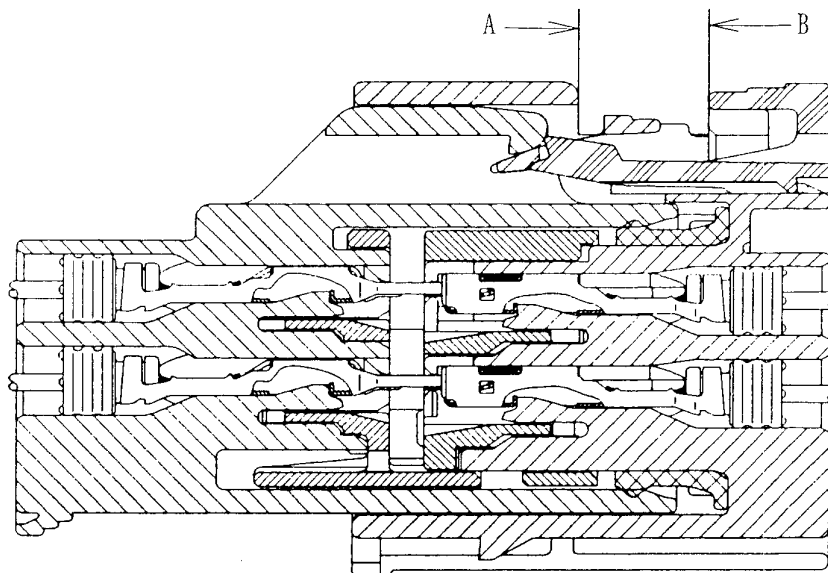

8-2. How to Unlock the CPA

The illustration below shows the CPA in a fully locked position. In order to release the CPA from the locked position, press and slide in direction of the arrow.

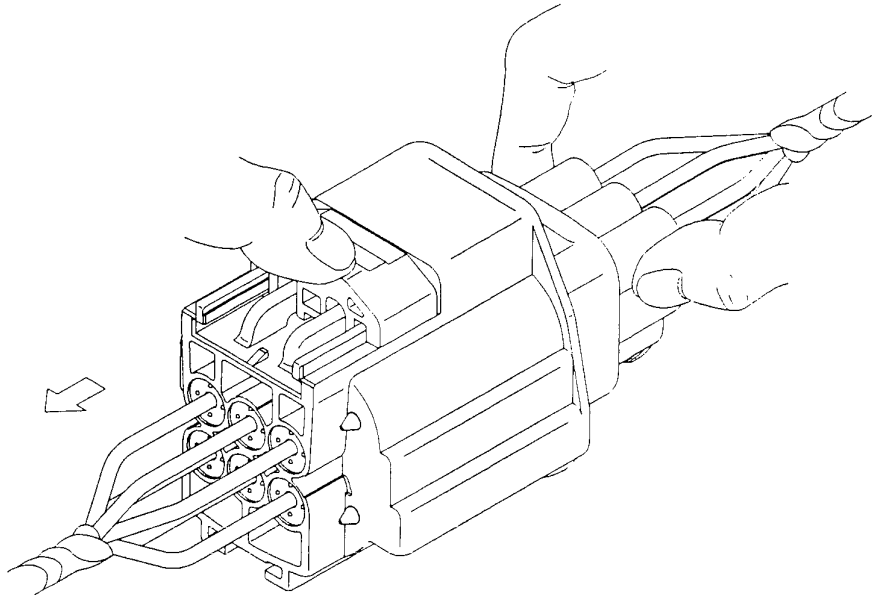



## 9. Precautions During Wire Harness Assembly

### 9-1. Wire Harness Assembly

- Avoid tangling the leads which could cause the terminated wires to become hooked and/or damaged.
- Because breakage may occur on wire seal of crimped terminal during transportation, operator should confirm no damage on the wire seal before usage.
- Wires of inadequate length should be discarded rather than forced into the connector. 'Stretching' of the circuit could result in wire breakage or housing/terminal damage.
- When ultrasonic is employed to connect components (terminal, wire, etc...), confirm that ultrasonic cause no negative effect on terminal and connector before the application.

### 9-2. Taping

Wires which will be taped should be of similar length. Taping of circuits of different length could result in a concentration of force on the shortest wire, resulting in Terminal Pull-Out.

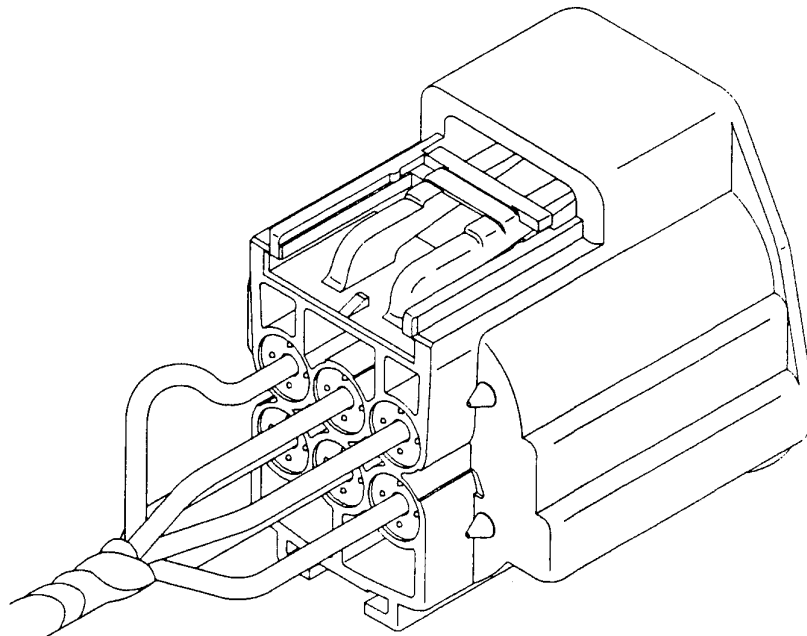

9-3. Precautions During Inspection

- Jigs used for routing and/or continuity inspection should be calibrated for the tolerance equivalent to that of the dimension of mating component. Use of jigs with greater tolerance variation than that of the mating component could result in damage to the housing and/or terminal.
- During routing inspection, in case a jig is used to contact female terminal, it should be calibrated for the tolerance equivalent to that of the dimension of male connector. Use of jigs with greater tolerance variation than that of male connector could result in damage to female terminal.
- A probe pin should be inserted for continuity inspection purpose. The recommended location for the insertion of the probe pin is shown in the illustration below (to prevent terminal spring deformation).

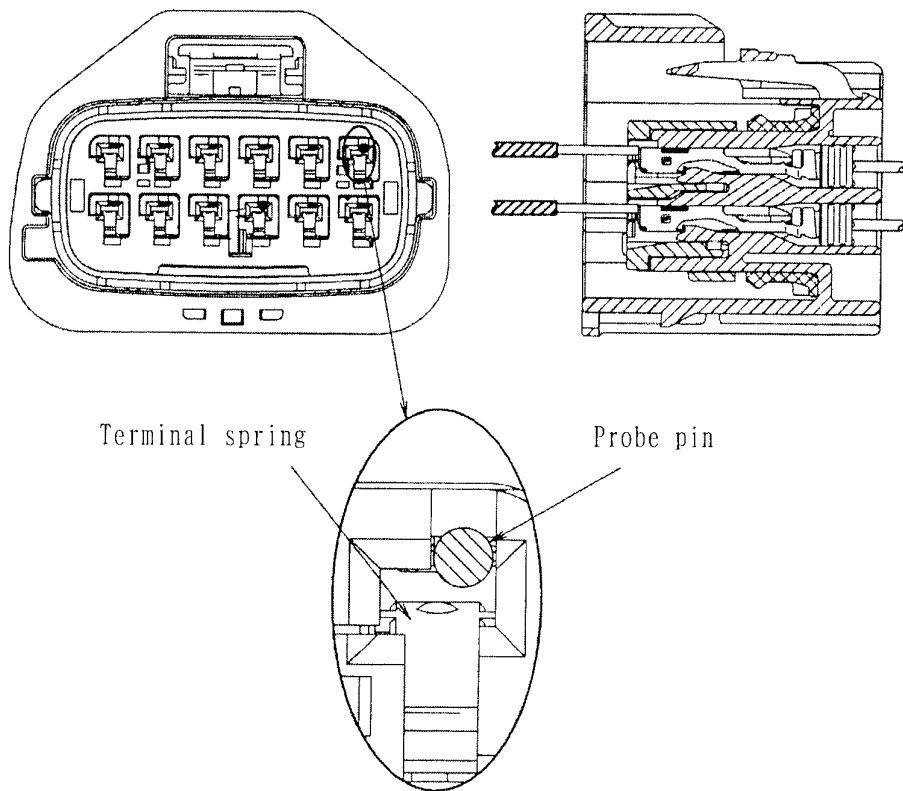

- Damaged and/or deformed housing/terminal should be replaced regardless the degree of damage/deformation.

10. Notice for Packing of Wire Harness

As with many plastic parts the connector may be damaged if external force is applied to the connector during transportation or storage. To prevent damages, please take the following actions as well as the standard packaging and handling procedures:

When packing wire harness in layers, please use paper corrugate/corrugate dividers for each layer, including layer dividers, vertical dividers, internal supports, and partitions to equally distribute weights of upper-layer harnesses from being unequally applied to the lower-layer harnesses, as shown below.

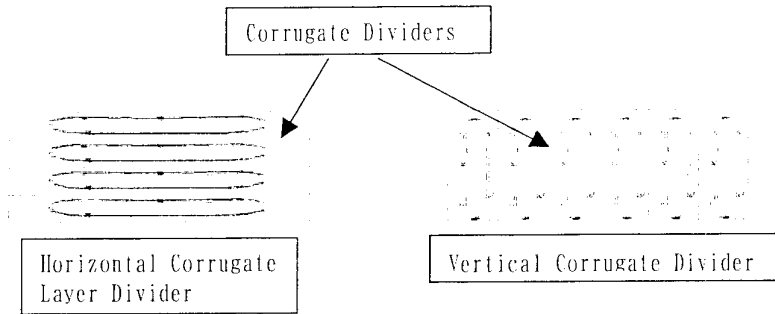

Junction block, relay box, protectors, brackets, and any heavy and/or bulky item must be placed on the bottom of the carton or the divider to prevent weight of such item from being applied to the connector as shown below.

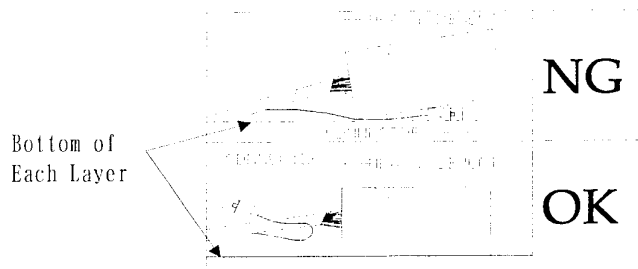

The connector must be positioned outside or in the center of the harness bundle, to prevent the weight of the harness from being applied to the connector

Sample harness sketch. Place connectors inside and outside of bundled W/H to protect connectors from weight of the W/H.

Wire harness bundle size must fit the carton to prevent shifting of wire harness during transportation or storage. See below illustration.

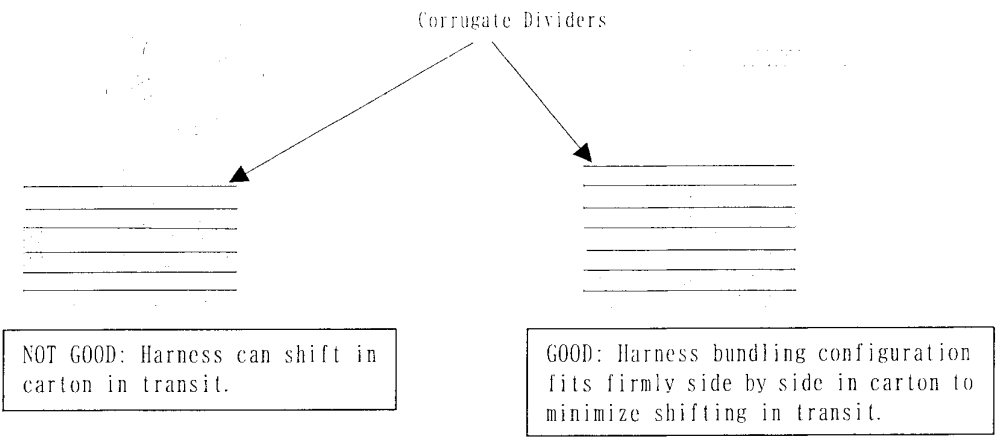

If the connector housing is 'taped back' on the wire harness bundle, assure that the housing lock or other flexible member of the connector is positioned away from the wire harness bundle. See reference illustration below.

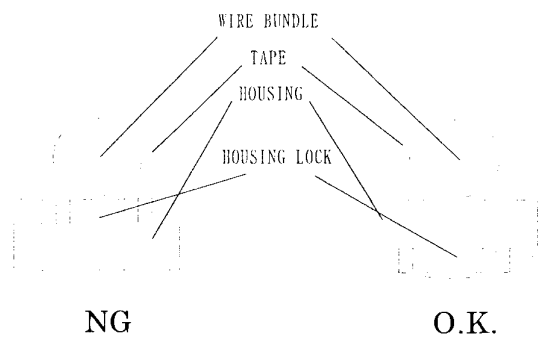

Extra care must be taken to prevent wire harnesses tangling which causes damages to the connector when the wire harness is removed from the carton at the vehicle assembly.

After transportation or storage, the connector must be checked for damages.

YAZAKI SHALL NOT BE LIABLE FOR ANY DAMAGES RESULTING FROM MISUSE OR FAILURE TO FOLLOW THE ABOVE INSTRUCTIONS

## 11. Precautions During Wire Harness Installation into the Vehicle

### 11-1. Connector Mating

Upon confirmation that the proper connectors are being mated (i. e. proper keyway is confirmed), the connectors should be smoothly mated. Unnecessary scooping or wrenching of the connectors should be avoided.

- Confirm that the front holder has been surely full-locked.  
(In case it has not been full-locked, refer to 5-2 and 5-3.)
- Push the connectors until "click" sound which locking beak is locked is heard.  
(During mating, do not press locking key.)
- Confirm that connectors have been surely mated by pulling male/female connectors lightly.

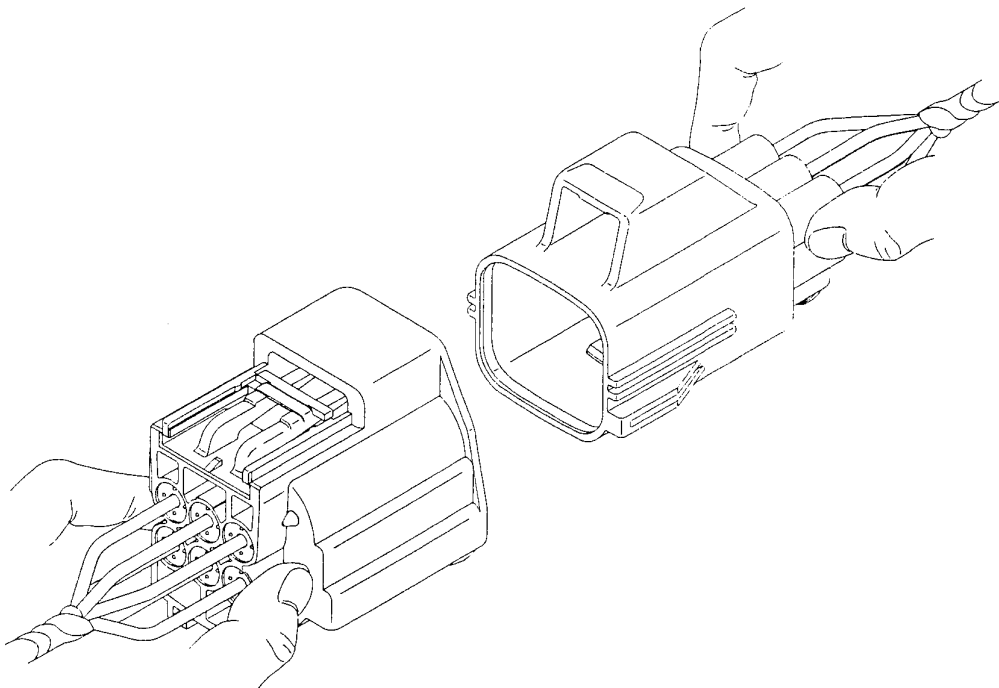

### 11-2. Connector Servicing

Connector disengagement can be facilitated by pulling the lever out and pulling apart the male and female connectors. During the removal process, the wires of the connector should not be held or pulled. Application of force to the wires could result in damage to the individual components of the connector.

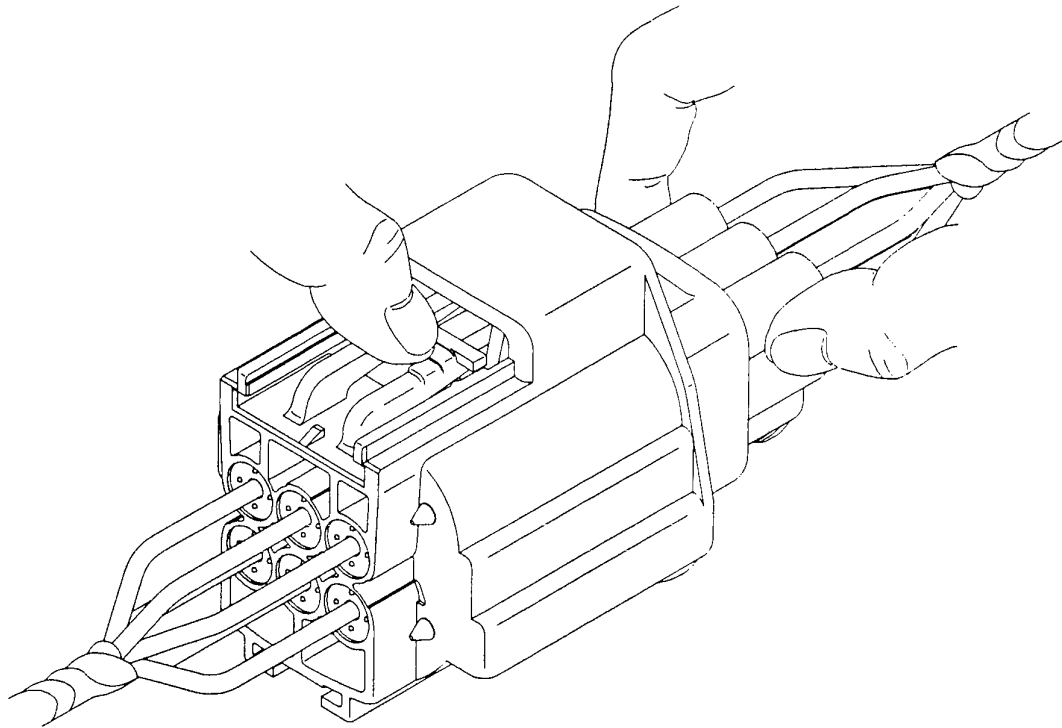

© Connector Configurations and Figures of Part Numbers

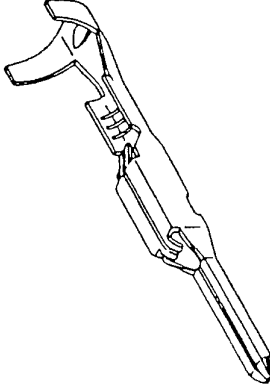
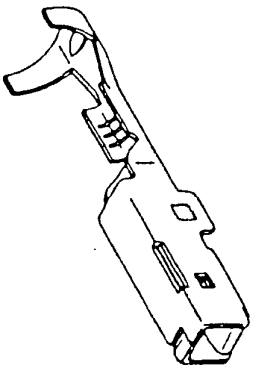
YAZAKI PART NO. (PART NAME)	SHAPE	APPLICABLE WIRE SIZE	REMARK
7114-4102-02 (1.5 SYSTEM CONNECTOR SEALED TERMINAL MALE TIN PLATING) 7114-4102-08 (GOLD PLATING)		0.35 ~ 0.5 mm <sup>2</sup> 22AWG ~ 20AWG	
7114-4103-02 (1.5 SYSTEM CONNECTOR SEALED TERMINAL MALE TIN PLATING) 7114-4103-08 (GOLD PLATING)		0.75 ~ 1.25 mm <sup>2</sup> 18AWG ~ 16AWG	
7116-4102-02 (1.5 SYSTEM CONNECTOR SEALED TERMINAL FEMALE TIN PLATING) 7116-4102-08 (GOLD PLATING)		0.35 ~ 0.5 mm <sup>2</sup> 22AWG ~ 20AWG	
7116-4103-02 (1.5 SYSTEM CONNECTOR SEALED TERMINAL FEMALE TIN PLATING) 7116-4103-08 (GOLD PLATING)		0.75 ~ 1.25 mm <sup>2</sup> 18AWG ~ 16AWG	
7116-4105-02 (1.5 SYSTEM CONNECTOR SEALED TERMINAL FEMALE TIN PLATING) ※ 1		1.50 ~ 2.0 mm <sup>2</sup> 14AWG	

※1 : Reference to next page.

Terminals for 1.5sys with 1.5mm<sup>2</sup> & over should be used only for those applications where excessive voltage drop in a small size wire may adversely affect the function of the circuit.

Maximum applied current on the wire of 1.5mm<sup>2</sup> & over for 1.5sys should not exceed 15A.  
 Maximum applied current recommendation based on Bench-Test results only.

(Test conditions: Single Circuit, 20°C Ambient, Open Air, 1.25mm<sup>2</sup> wire, 20°C ROA.)  
 Appropriate de-rating should be considered based on specific application requirements (Ambient Temperature, Pole Quantity, Wire Size, etc.)

Description	Max Wire Size	Wire Sizes for Applications with Excessive Voltage Drop	Max Current Recommendation <sup>1)</sup>
1.5sys	1.25mm <sup>2</sup>	1.5mm <sup>2</sup> or 2.0mm <sup>2</sup> 3)	15A

- 1) Single Circuit, 20°C Ambient, Open Air and 20°C ROA with Max Wire
- 2) 1.25mm<sup>2</sup> = 16AWG
- 3) 2.0mm<sup>2</sup> = 14AWG

<Appendix> Applicable Wire Size for Sealed YESC

Wire Size	AWG	22	20	18	16	14
	ISO(mm <sup>2</sup> )	0.35	0.5	0.75	1.0	1.5
1.5sys	Male	O	O	O	O	x
	Female	O	O	O	O	Δ

O : Acceptable  
 x : Not Acceptable  
 Δ : Terminals for Voltage Drop Issue

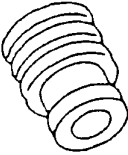
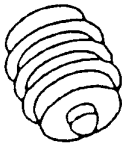
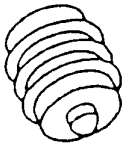

YAZAKI PART NO. (PART NAME)	SHAPE	WIRE OVERALL DIAMETER	REMARK
7158-3030-50 (1.5 SYSTEM SEALED CONNECTOR RUBBER STOPPER)		φ 1.20 ~ φ 1.70	COLOR : RED
7158-3031-90 (1.5 SYSTEM SEALED CONNECTOR RUBBER STOPPER)		φ 1.63 ~ φ 2.20	COLOR : BLUE
7158-3032-60 (1.5 SYSTEM SEALED CONNECTOR DUMMY PLUG)		_____	COLOR : GREEN

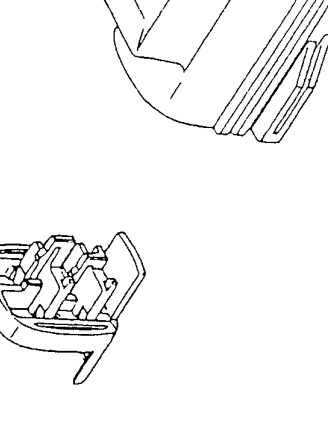
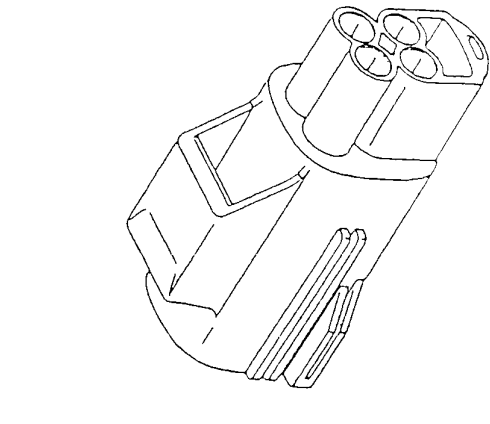
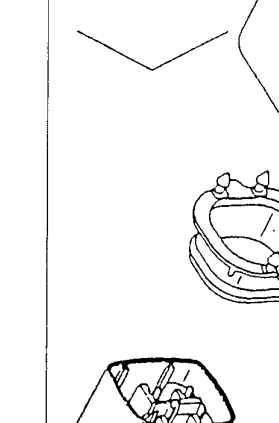
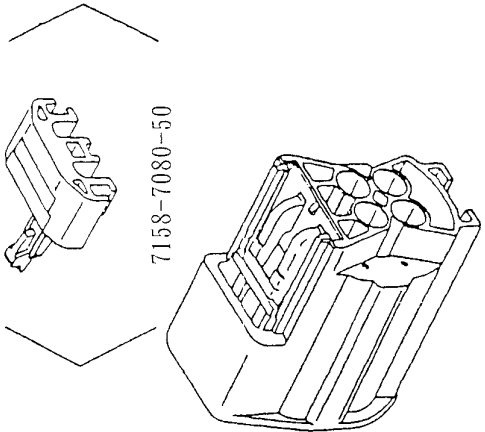
YAZAKI PART NO. (PART NAME)	SHAPE	CONSTRUCTION (PART NO. AND SHAPE)
<p>7282-5543-10 (1.5 SYSTEM SEALED CONNECTOR 4P MALE) (TYPE-A)</p>		
<p>7283-5543-10 (1.5 SYSTEM SEALED CONNECTOR 4P FEMALE) (TYPE-A)</p> <p>7283-5544-10 (with CPA)</p>		

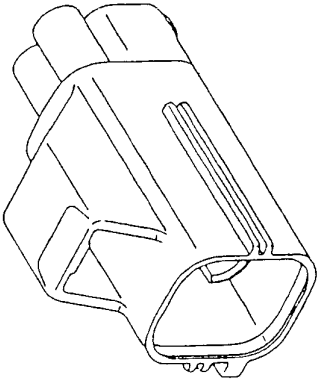
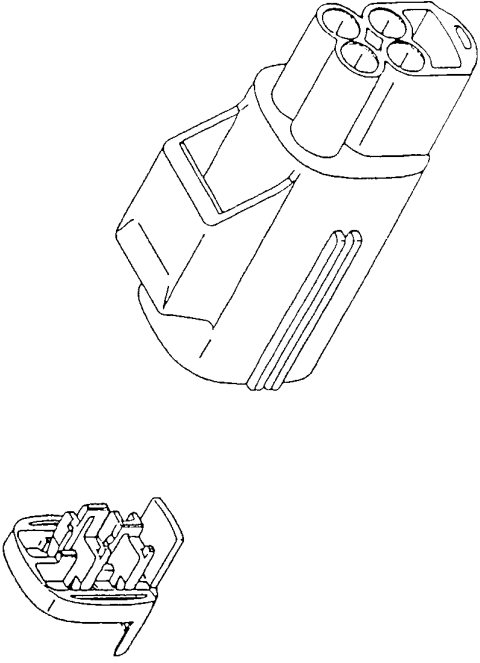
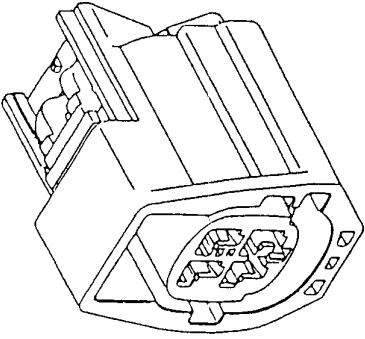
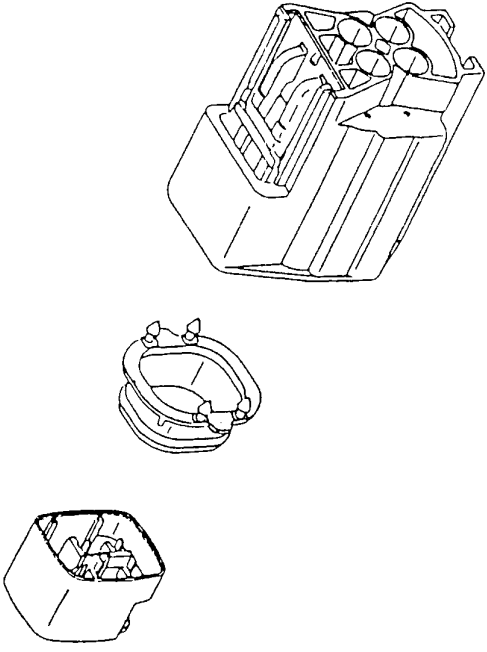
YAZAKI PART NO. (PART NAME)	SHAPE	CONSTRUCTION (PART NO. AND SHAPE)
<p>7282-5889-30 (1.5 SYSTEM SEALED CONNECTOR 4P MALE) (TYPE-B)</p>		
<p>7283-5889-30 (1.5 SYSTEM SEALED CONNECTOR 4P FEMALE) (TYPE-B)</p>		

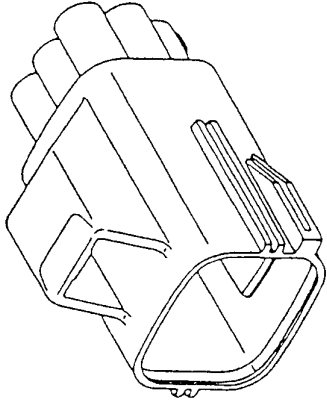
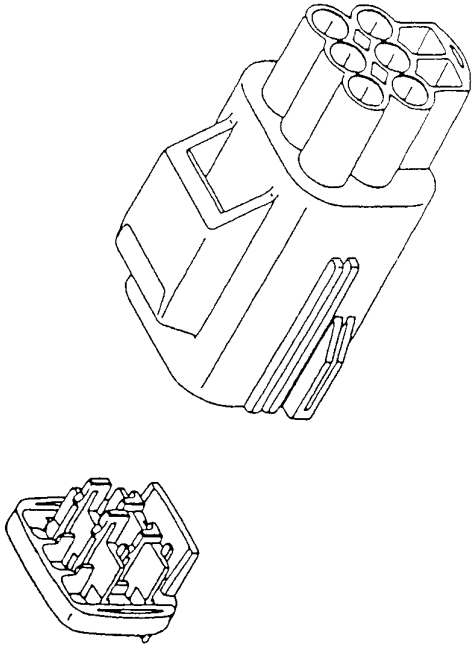
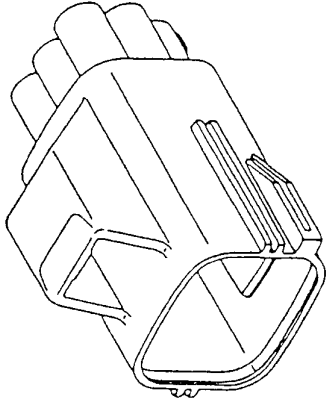
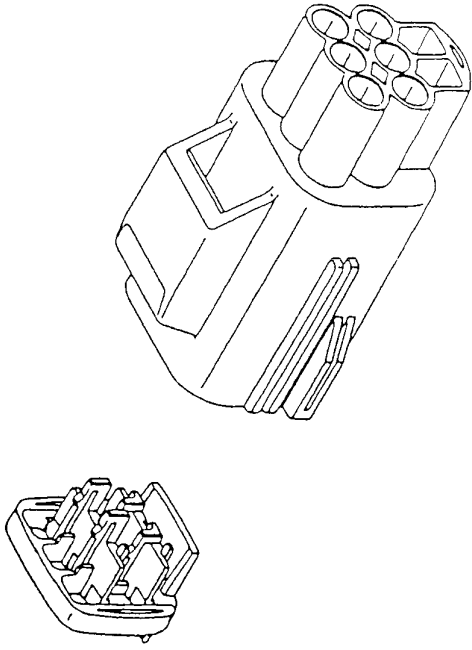
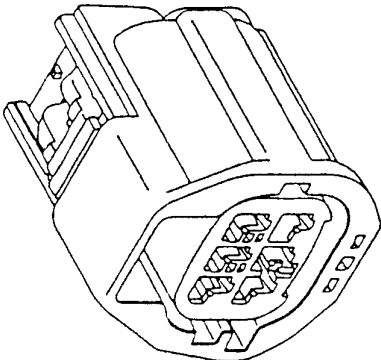
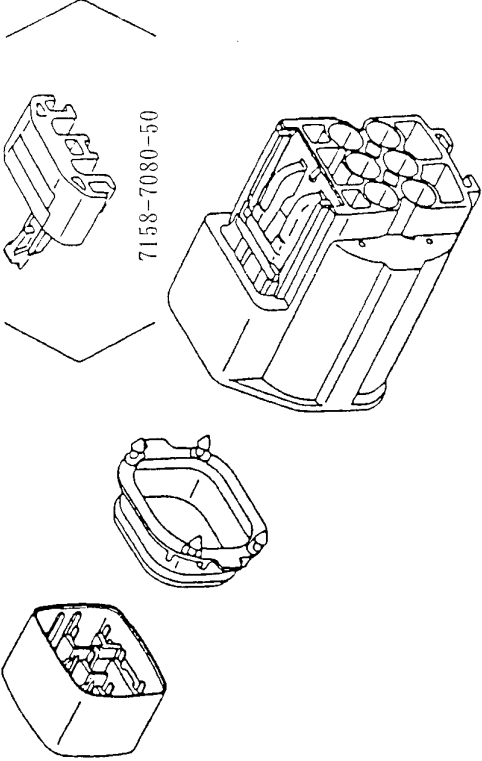
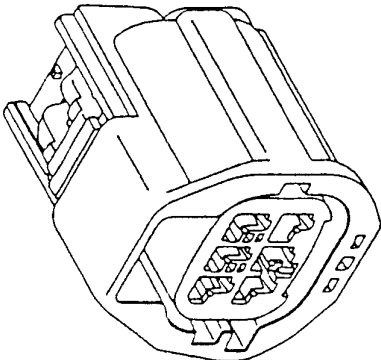
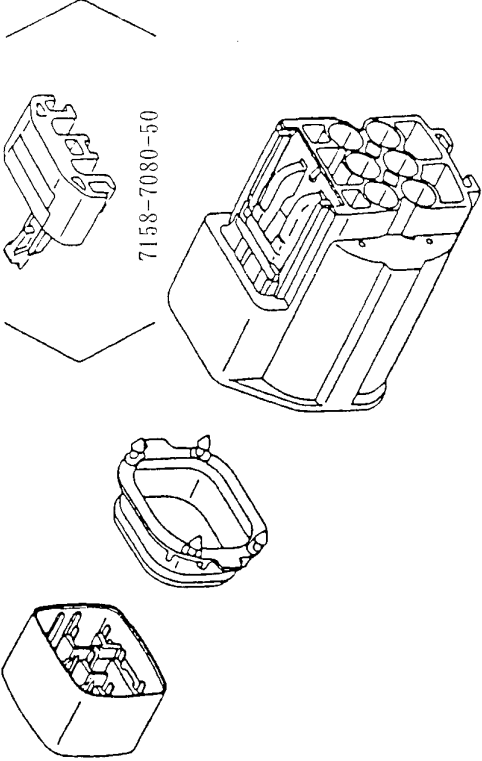
YAZAKI PART NO. (PART NAME)	SHAPE	CONSTRUCTION (PART NO. AND SHAPE)
7282-5553-10 (1.5 SYSTEM SEALED CONNECTOR 6P MALE)		
7282-5553-30 (1.5 SYSTEM SEALED CONNECTOR 6P MALE)		
7283-5553-10 7283-5553-30 (1.5 SYSTEM SEALED CONNECTOR 6P FEMALE)		
7283-5554-10 7283-5554-30 (1.5 SYSTEM SEALED CONNECTOR 6P FEMALE) (with CPA)		

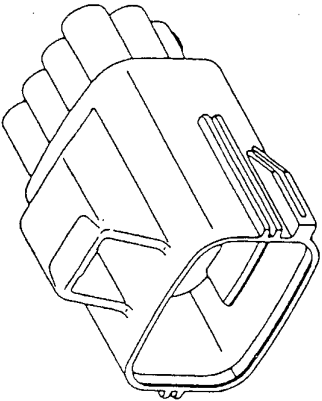
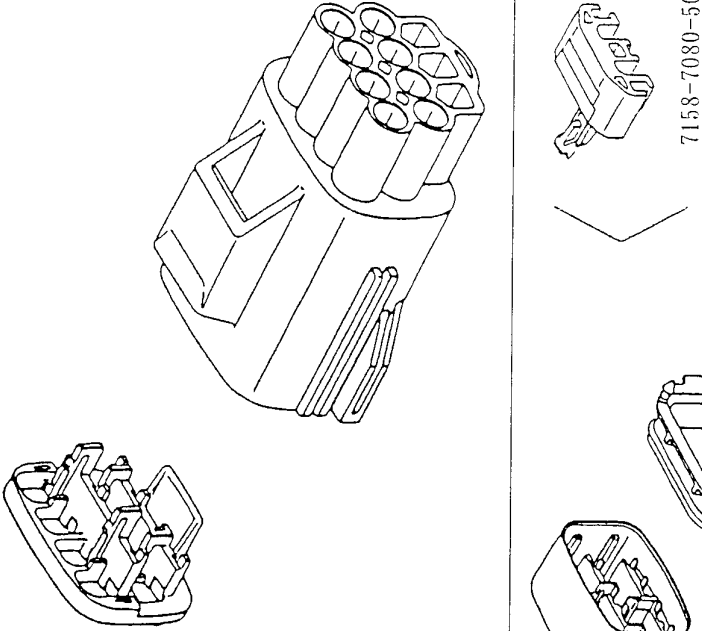
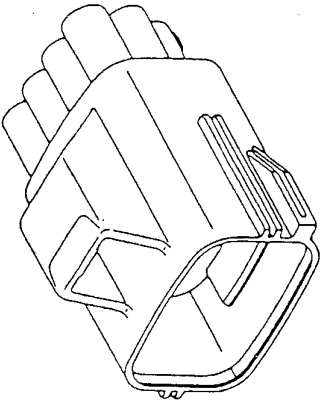
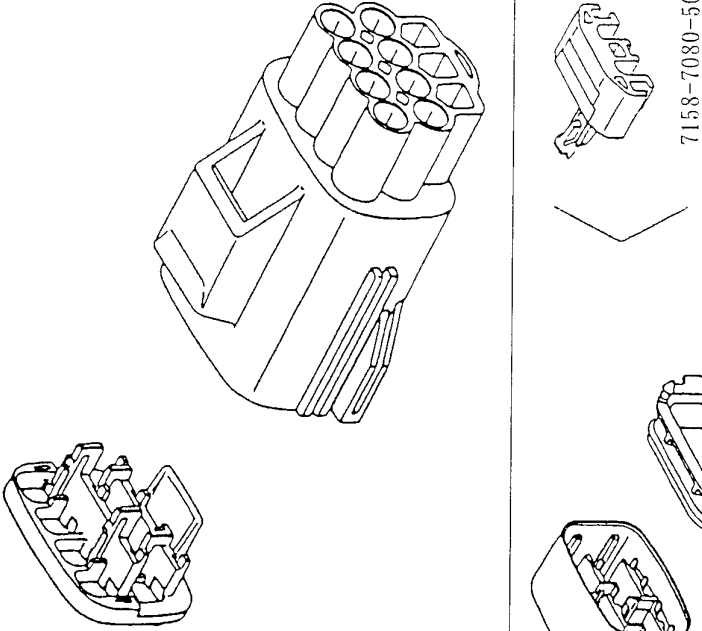
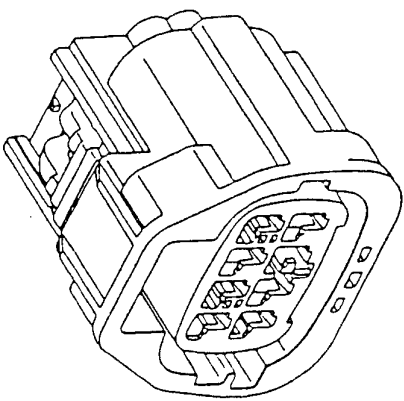
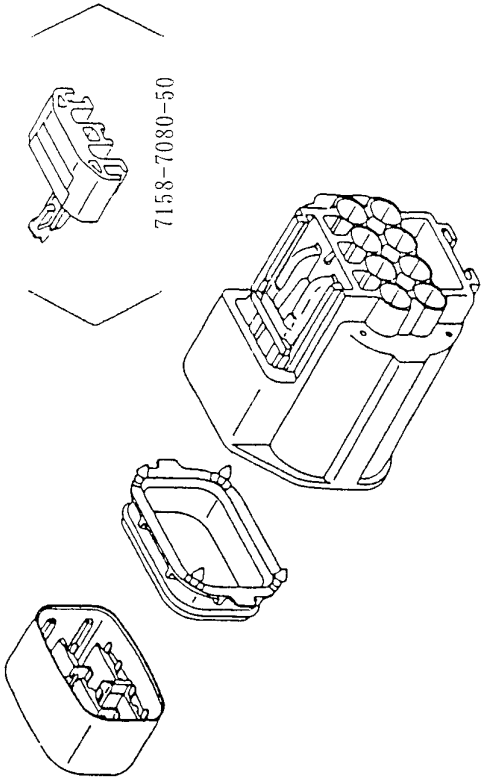
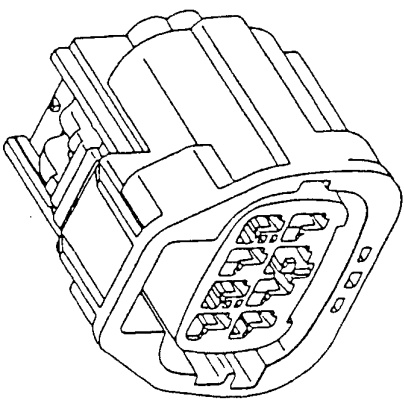
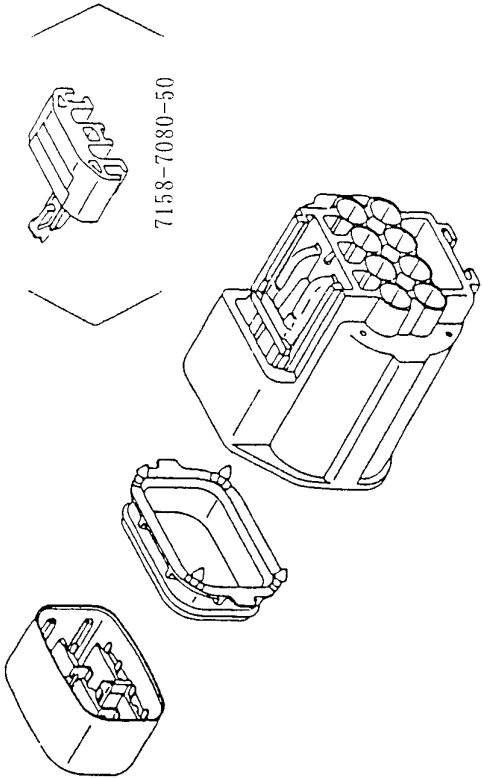
YAZAKI PART NO. (PART NAME)	SHAPE	CONSTRUCTION (PART NO. AND SHAPE)
7282-5684-10 (1.5 SYSTEM SEALED CONNECTOR 8P MALE)		
7282-5684-30 (1.5 SYSTEM SEALED CONNECTOR 8P MALE)		
7283-5684-10 7283-5684-30 (1.5 SYSTEM SEALED CONNECTOR 8P FEMALE)		
7283-5685-10 7283-5685-30 (1.5 SYSTEM SEALED CONNECTOR 8P FEMALE) (with CPA)		

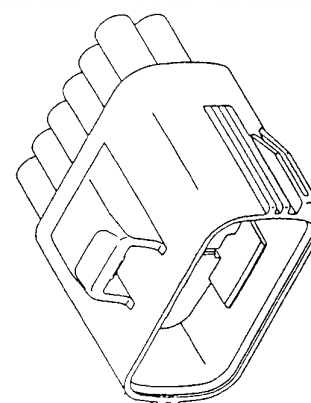
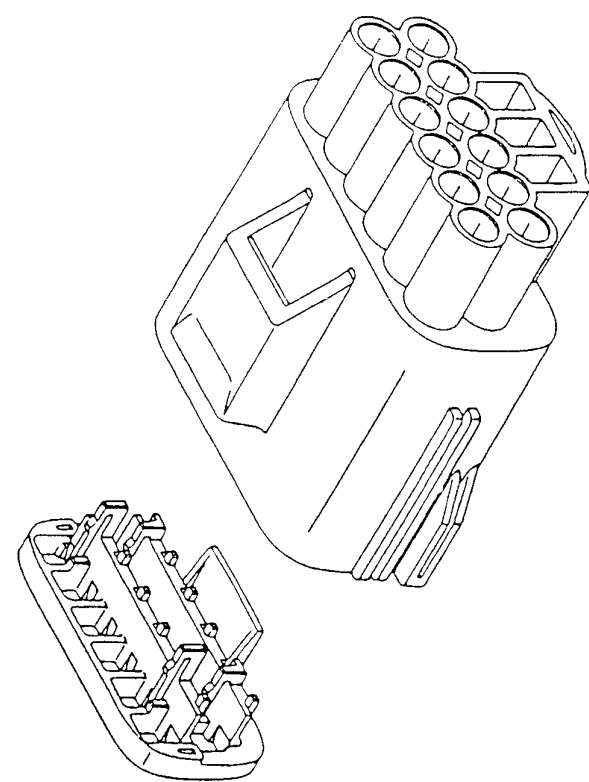
YAZAKI PART NO. (PART NAME)	SHAPE	CONSTRUCTION (PART NO. AND SHAPE)
7282-5545-10 (1.5 SYSTEM SEALED CONNECTOR 12P MALE)		
7282-5545-30 (1.5 SYSTEM SEALED CONNECTOR 12P MALE)		

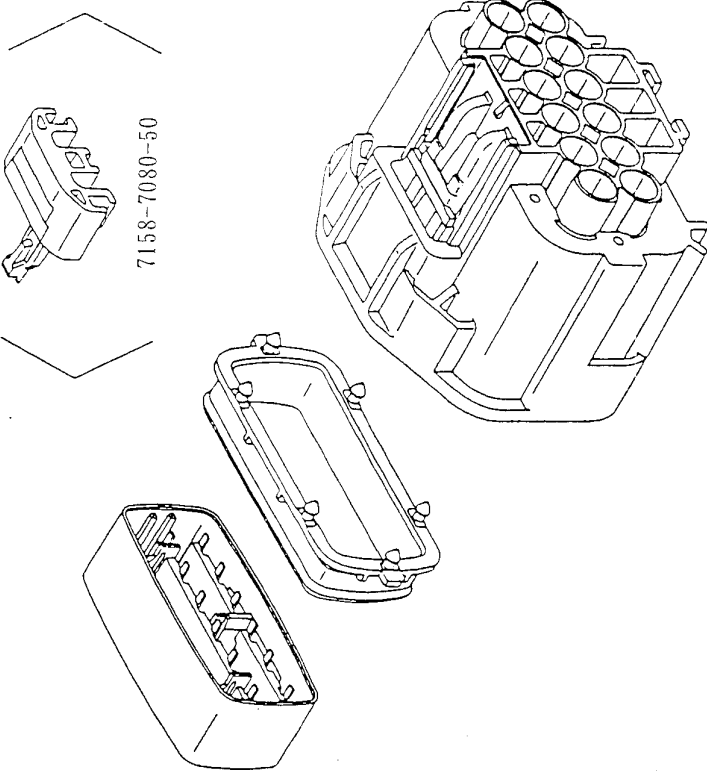
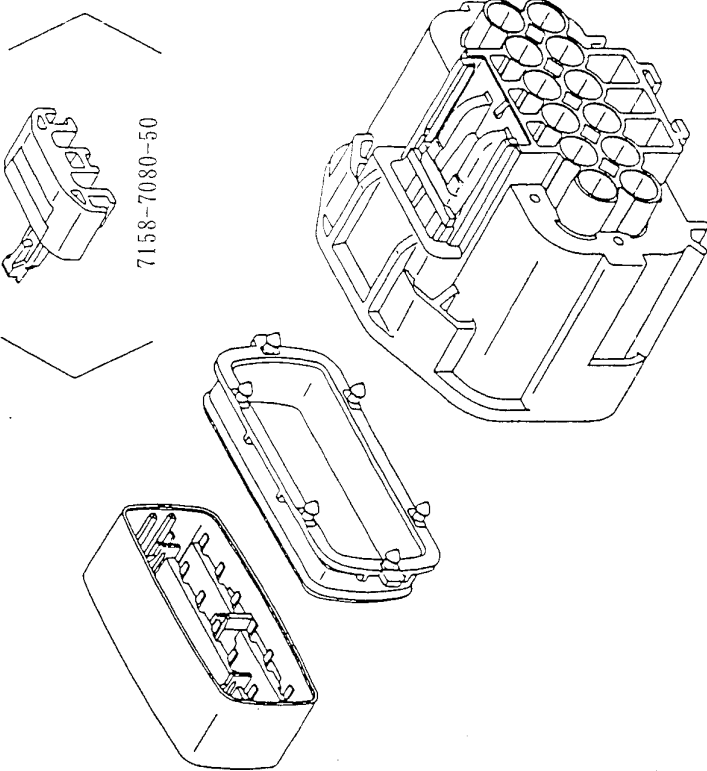
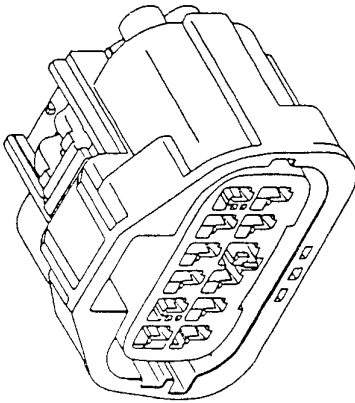
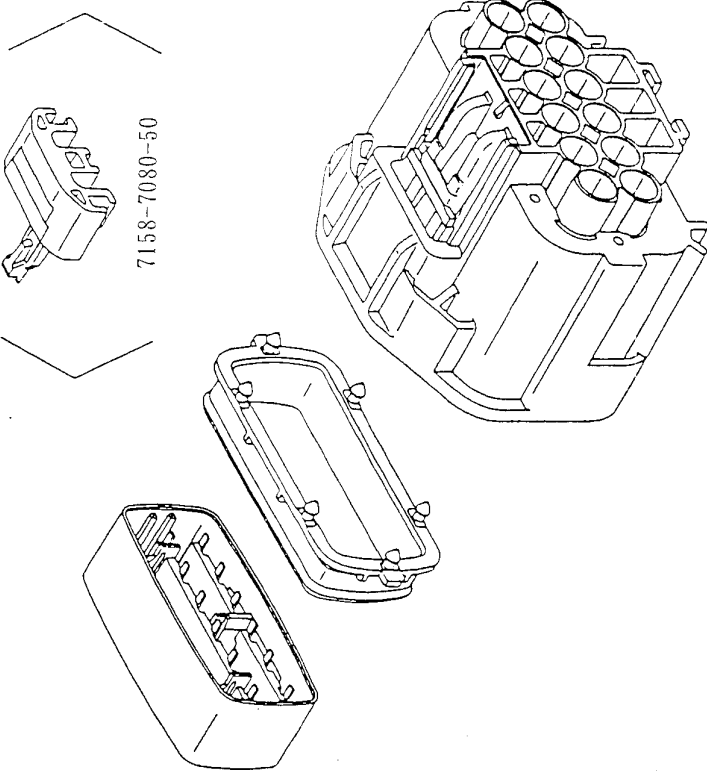
YAZAKI PART NO. (PART NAME)	SHAPE	CONSTRUCTION (PART NO. AND SHAPE)
<p>7283-5545-10 7283-5545-30 (1.5 SYSTEM SEALED CONNECTOR 12P MALE)</p>		
<p>7283-5546-10 7283-5546-30 (1.5 SYSTEM SEALED CONNECTOR 12P FEMALE (with CPA)</p>		

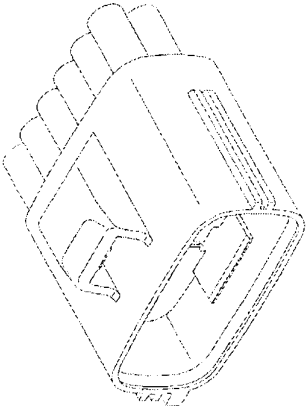
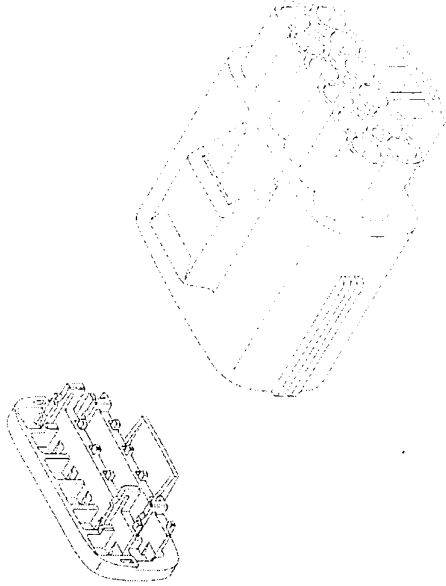
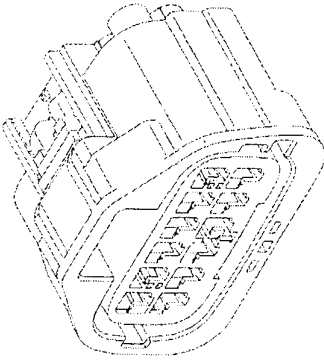
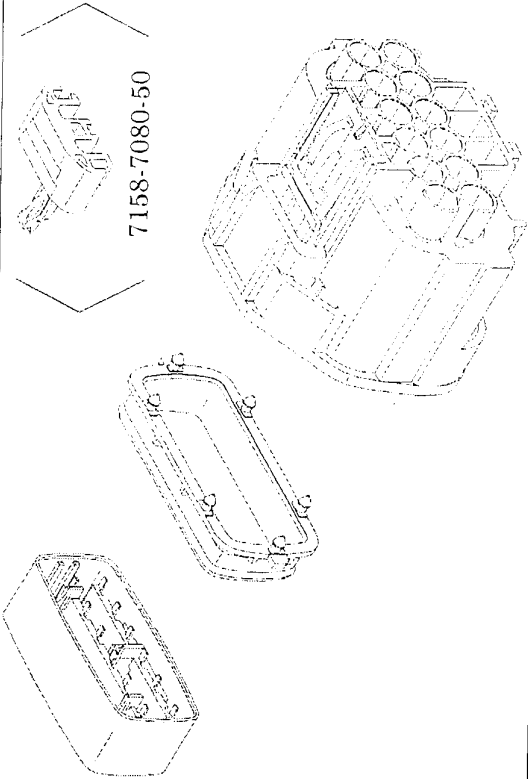
YAZAKI PART NO. (PART NAME)	SHAPE	CONSTRUCTION (PART NO. AND SHAPE)
<p>7282-5968-40 (1.5 SYSTEM SEALED CONNECTOR 12P MALE) (TYPE-B)</p>		
<p>7283-5968-40 (1.5 SYSTEM SEALED CONNECTOR 12P FEMALE) (TYPE-B)</p> <p>7283-5969-40 (With CPA)</p>		



## List of Other Connectors Part Number(Isometric drawing in progress)

YAZAKI PART NO.	YAZAKI PART NAME	REMARK
7283-5548-30	1.5 SYSTEM SEALED CONN. 2P(F) TYPE-A	
7283-5549-30	1.5 SYSTEM SEALED CONN. 2P(F) TYPE-A WITH CPA	
7282-5548-30	1.5 SYSTEM SEALED CONN. 2P(M) TYPE-A	
7283-5558-10	1.5 SYSTEM SEALED CONN. 2P(F) TYPE-B	
7283-5559-10	1.5 SYSTEM SEALED CONN. 2P(F) TYPE-B WITH CPA	
7282-5558-10	1.5 SYSTEM SEALED CONN. 2P(M) TYPE-B	
7283-5689-30	1.5 SYSTEM SEALED CONN. 2P(F)	
7283-5541-30	1.5 SYSTEM SEALED CONN. 3P(F) TYPE-A	
7283-5542-30	1.5 SYSTEM SEALED CONN. 3P(F) TYPE-A WITH CPA	
7282-5541-30	1.5 SYSTEM SEALED CONN. 3P(M) TYPE-A	
7283-5691-10	1.5 SYSTEM SEALED CONN. 3P(F) TYPE-B	
7283-5880-10	1.5 SYSTEM SEALED CONN. 3P(F) TYPE-B WITH CPA	
7283-5882-80	1.5 SYSTEM SEALED CONN. 3P(F) TYPE-C	
7283-5883-80	1.5 SYSTEM SEALED CONN. 3P(F) TYPE-C WITH CPA	
7283-5885-30	1.5 SYSTEM SEALED CONN. 4P(F)	
7283-5886-30	1.5 SYSTEM SEALED CONN. 4P(F) WITH CPA	
7283-5547-30	1.5 SYSTEM SEALED CONN. 5P(F)	
7283-5550-30	1.5 SYSTEM SEALED CONN. 5P(F) WITH CPA	
7283-5946-30	1.5 SYSTEM SEALED CONN. 10P(F) TYPE-A	
7283-5947-30	1.5 SYSTEM SEALED CONN. 10P(F) TYPE-A WITH CPA	
7282-5946-30	1.5 SYSTEM SEALED CONN. 10P(M) TYPE-A	
7283-5696-30	1.5 SYSTEM SEALED CONN. 10P(F)	
7283-5697-30	1.5 SYSTEM SEALED CONN. 10P(F) WITH CPA	
7283-5693-10	1.5 SYSTEM SEALED CONN. 10P(F) WITH CPA	
7283-5694-10	1.5 SYSTEM SEALED CONN. 10P(F) WITH CPA	
7283-5694-40	1.5 SYSTEM SEALED CONN. 10P(F) WITH CPA	
7283-5948-10	1.5 SYSTEM SEALED CONN. 10P(F)	
7283-5695-10	1.5 SYSTEM SEALED CONN. 10P(F) WITH CPA	
7283-5695-30	1.5 SYSTEM SEALED CONN. 10P(F) WITH CPA	